

Improving The Controllability of Grid-Tie Inverter for Small-Scale Rooftop Photovoltaic System

Van-Phong Vu, Dinh-Nhon Truong*, An-Quoc Hoang

Ho Chi Minh City University of Technology and Education, Ho Chi Minh City. Vietnam

* Corresponding author. Email: nhontd@hcmute.edu.vn

ARTICLE INFO

Received: 17/12/2021
Revised: 26/1/2022
Accepted: 06/2/2022
Published: 28/2/2022

ABSTRACT

This paper aims to apply an Adaptive Network-based Fuzzy Inference System (ANFIS) controller in a DC-link voltage regulator to decrease the power fluctuation for enhancing the performance of the grid-tie inverter for a small-scale rooftop solar Photovoltaic (PV) system. For tracking Maximum Power Point (MPP), a Perturb and Observe (P&O) algorithm was presented. To demonstrate the effectiveness of the proposed controllers for a small-scale 5 kWp rooftop solar PV system, several time-domain simulation results under a three-phase short-circuit fault that happened at a grid-tie inverter system was systematically performed by employing Matlab/Simulink toolbox. On the basis of the simulation results, it is obvious that the proposed P&O algorithm for MPP tracking and the designed ANFIS controller for DC-link voltage regulator of the grid-tie inverter shows better performance to reduce overshoot and settling time in transient responses of the studied small-scale 5 kW grid-tie rooftop solar PV inverter under the most severe operating condition.

KEYWORDS

Grid-tie inverter;
Solar PV;
Perturb and Observe;
ANFIS;
MPP.

Doi: <https://doi.org/10.54644/jte.68.2022.1096>

Copyright © JTE. This is an open access article distributed under the terms and conditions of the [Creative Commons Attribution-NonCommercial 4.0 International License](https://creativecommons.org/licenses/by-nc/4.0/) which permits unrestricted use, distribution, and reproduction in any medium for non-commercial purpose, provided the original work is properly cited.

1. Introduction

Photovoltaic (PV) becomes one of the important renewable energy sources. In particular, rooftop solar power has been growing rapidly in recent times. In addition to generating electricity for the load, just 1-kWp of rooftop solar capacity will help reduce carbon dioxide emissions by 28 tons [1]. Some research results show that the decision to invest in distributed power generation systems using rooftop solar PV power depends significantly on technology costs, national financial conditions, and tariffs. Therefore, it is necessary to study and evaluate the feasibility of these projects [2-3].

For optimizing the capacity of the solar PV system, many algorithms have been suggested for Maximum Power Point Tracker (MPPT) techniques [4, 5]. Besides, Battery Energy Storage (BES) is suggested for grid-connected households to minimize the net present cost of electricity [6]. However, the obtained data in a year from the practical projects demonstrated that the technology, national financial conditions, and tariffs were dramatically impacted the investment decisions [7,8].

To reduce investment costs for rooftop solar power systems, the solution of using grid-connected inverters without BES is prioritized for research. For instance, the power quality was improved by applying a Shunt Series Switched Grid Tied Inverter (SSS-GTI) [9]. With the aid of bidirectional switches, SSS-GTI is able to work under the shunt or cascade-connected mode. Grid-tie inverter using a new type of buck in buck, boost in boost was investigated in [10] to enhance the capacity by decreasing the switching losses in a 4-kW system with and without solar PV input.

In order to deal with the power quality issues affected by the switching of small-scale grid-tie solar PV inverters under the working conditions of PV systems mentioned in [11], in this paper, the ANFIS controller will be applied for the PV system to enhance the stability of the system using a grid-tie inverter.

The content of this paper is including The Introduction, the Studied system configuration, the ANFIS controller design, Simulation Results, and Conclusions are introduced in Section I to Section V, respectively.

2. Structure of the PV system

The proposed system configuration is introduced in Fig. 1 which is including a 5-kWp rooftop solar PV system connected to the power grid via a solar grid-tie inverter and a filter is installed in series with an inverter to improve the voltage quality.

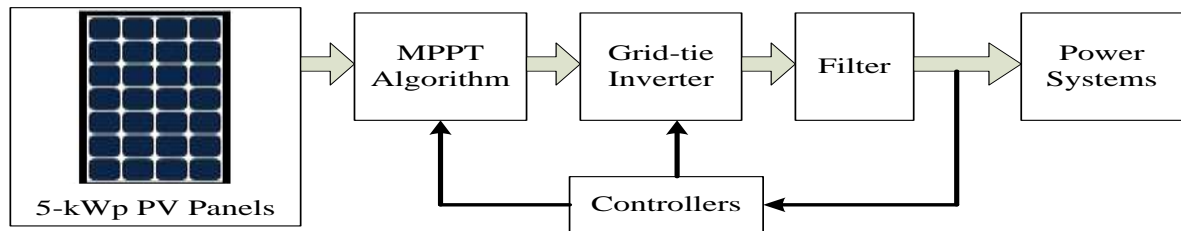

Figure 1. Configuration of the PV system

2.1 PV System Model

A PV array is described under an equivalent circuit diagram illustrated in Fig. 2. This circuit consists of a light-generated current I_L (A), a diode, a shunt resistor R_{sh} (Ω), and a series resistor R_s (Ω). The mathematical model of this system is referred to [4].

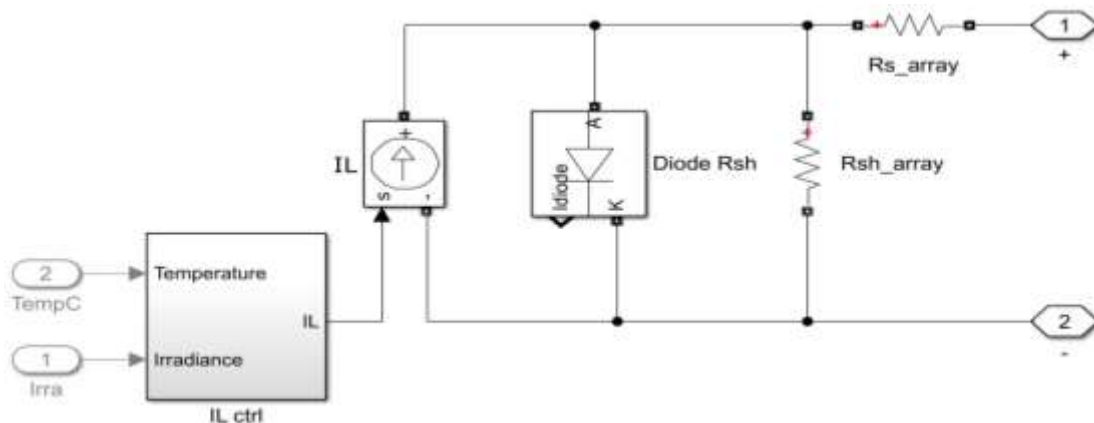

Figure. 2. The equivalent circuit diagram of a PV array in Matlab/Simulink

In this article, a Sunpower SPR-415E-WHT-D PV panel is chosen with the rated parameters are illustrated in Table I. The I-V and P-V curves for a rated 5-kWp PV system impacted by irradiance are respectively presented in Fig. 3 and Fig. 4.

2.2. P&O Algorithm for MPP Tracking

To obtain the optimal power of the PV system that included PV panels, boost inverter, and load, in this paper, an MPP tracker using Perturb and Observe (P&O) is suggested with the flowchart illustrated in Fig. 4. since P&O algorithm is considered the most popular method to track the MPP of the PV system [5].

In this flowchart, it is seen that a slight perturbation can make the power of the solar module change. In case, the power grows up due to the perturbation, the perturbation is continued in the same direction [4, 5, 12]. After the maximum power is obtained the power decreases the perturbation will reverse in the opposite direction to keep the steady-state oscillates around the peak point.

Table 1. Sunpower SPR-415E-WHT-D PV data

No.	Parameters	Values
1	Maximum Power (W)	414.8
2	Number of Cell per module	128
3	Open circuit Voltage (V)	85.3
4	Voltage at Maximum Power Point (V)	72.9
5	Short-circuit Current (A)	6.09
6	Current at Maximum Power Point (A)	5.69

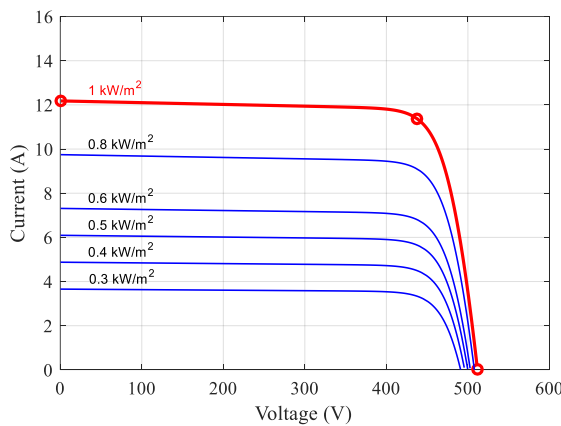

(a)

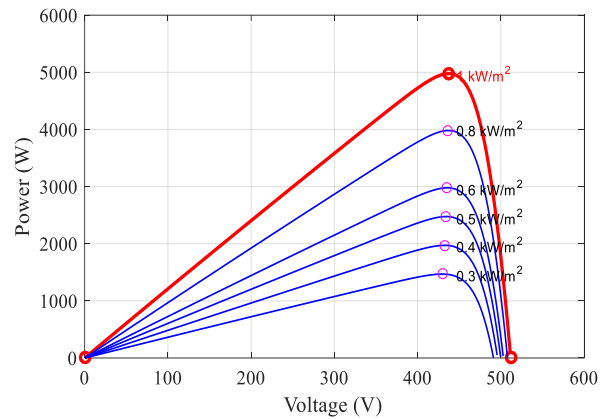

(b)

Figures. 3. Irradiance effect on the I-V and P-V curves: (a) I-V curve of PV array, (b) P-V curve of PV array.

3. ANFIS Controller Design

In this research paper, an ANFIS controller is synthesized to control the voltage of DC-link in the grid-tie inverter for a 5-kWp rooftop PV that aims to replace the traditional PI controller system as presented in Fig. 5.

The structure of ANFIS is referred to [13, 14]. However, to increase the accuracy of this controller, additional information from the load is added to the training data for the ANFIS controller.

Table 2. The parameters of ANFIS

Parameters	Quantity
Nodes	35
Linear Parameters	27
Nonlinear Parameter	24
Total parameters	51
Training data pairs	99001
Fuzzy rules	9

For this proposed strategy, the surface rule is depicted in Fig. 6, the minimal training error is RMSE = 0.046243.

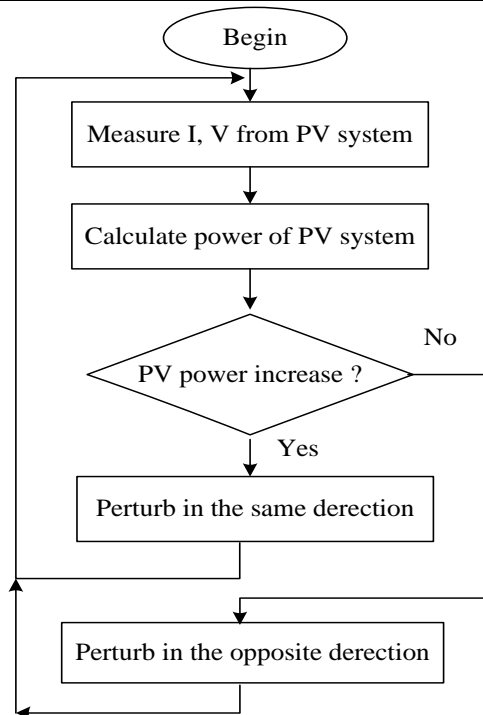

Figure 4. Flowchart of the P&O algorithm

4. Simulation Results

In this section, to be able to simulate the results in the time-domain, mathematical models of the system must be established. However, due to the limitation of the page number in the paper, the author only presents the application of the Simulink toolbox of Matlab software to show the simulation results, the mathematical model is referred to in the references [12-15]. The simulation results of the nonlinear system are provided to compare the P&O algorithm for MPP tracking and the proposed ANFIS controller when they are applied to control the grid-tie inverter for a rooftop PV system. These simulation results show that the dynamic stability of the PV system under different operating conditions is improved.

The simulation results are executed in Matlab/Simulink toolbox. with the blue lines presented for the responses of the system using the PI controller and ANFIS controller are shown in the blue and red lines, respectively.

Fig. 7 presents the response of the system with varying solar irradiance to see the maximum point detection ability of the designed P&O algorithm. It is seen that the P&O controller assists to obtain the maximum power of the PV system. Moreover, thanks to the ANFIS controller for the DC-link, the oscillation is greatly reduced.

To further evaluate the superiority of the two designed controllers, the performances of the system using the PI controller (blue lines) and ANFIS controller (red lines) when a three-phase short-circuit fault happened in 5-cycle at the power system (at 2.5 seconds) and the load (at 4.5 seconds), respectively are illustrated in Fig. 8 and Fig. 9. The simulation results in these figures show that the response of the PV system will fluctuate when the faults occur. But, when the faults are cleared after 5-cycles system returns normal operation after transients. In almost all cases, thanks to the ANFIS controller, transient fluctuations are better controlled than with the PI controller.

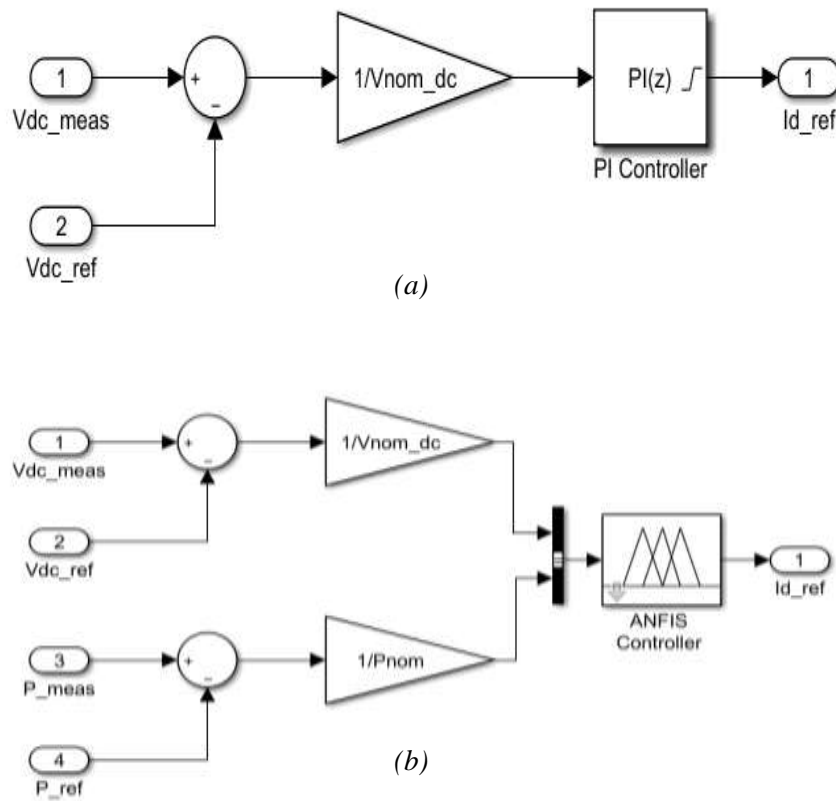

Figure 5. Controllers for DC-link voltage of solar inverter: (a) PI controller for DC-link voltage, (b) ANFIS controller for DC-link voltage

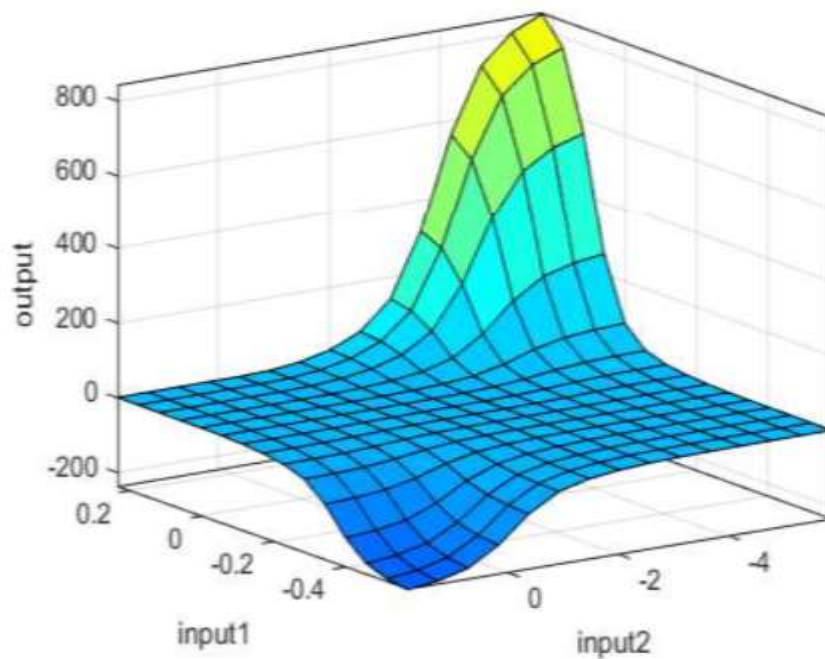

Figure 6. Surface rule of the designed ANFIS.

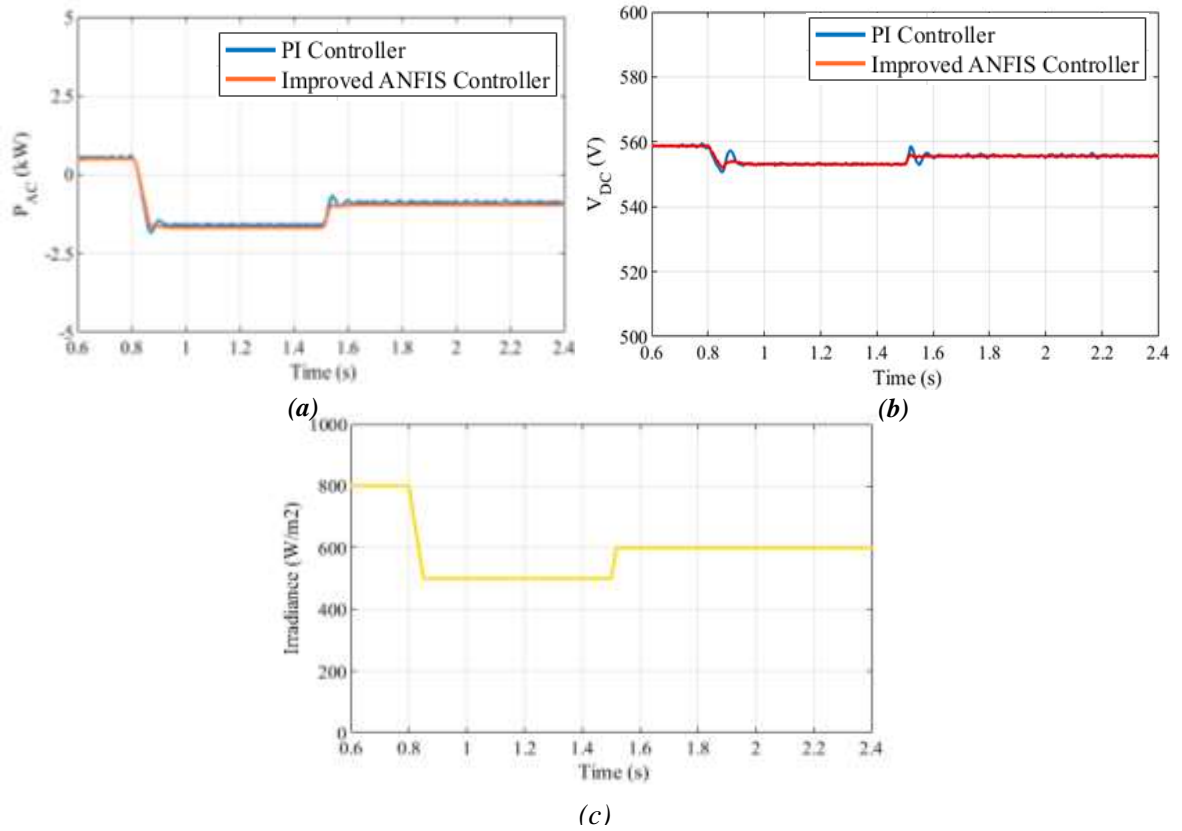
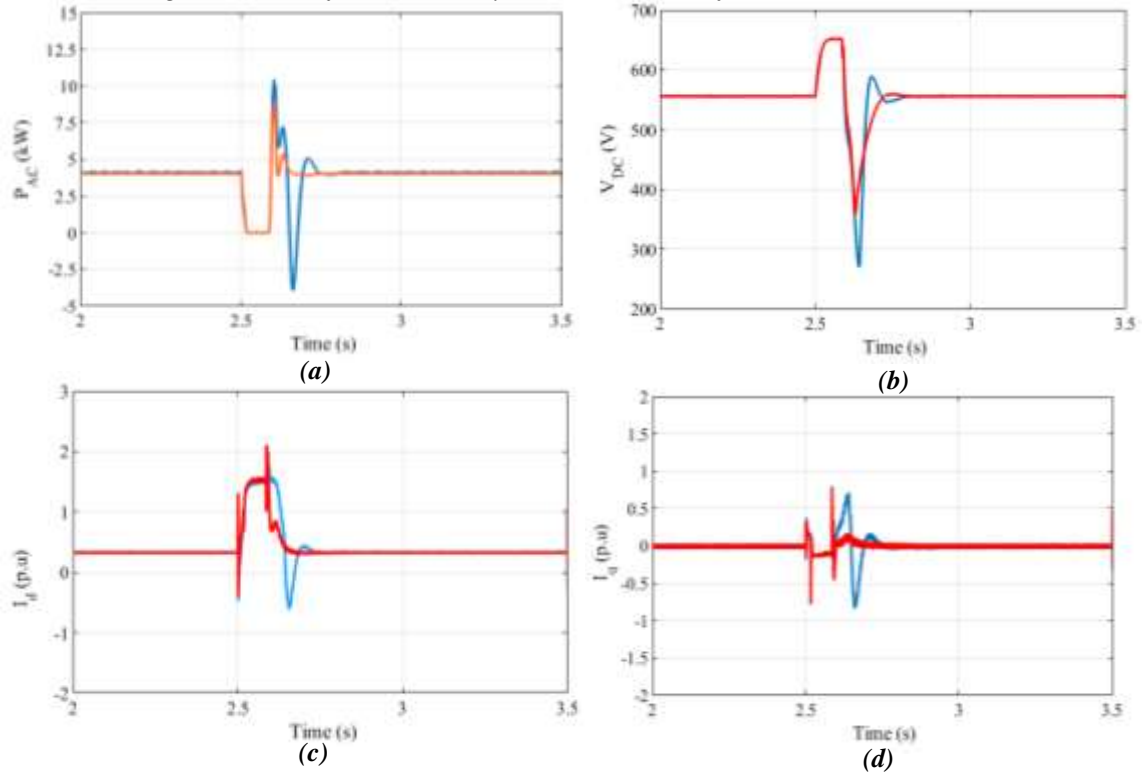

Figure 7. Responses of studied system when when irradiance changing: (a) Active power of the solar PV system, (b) Voltage at DC-link of the solar PV system, (c) Variation of the irradiance



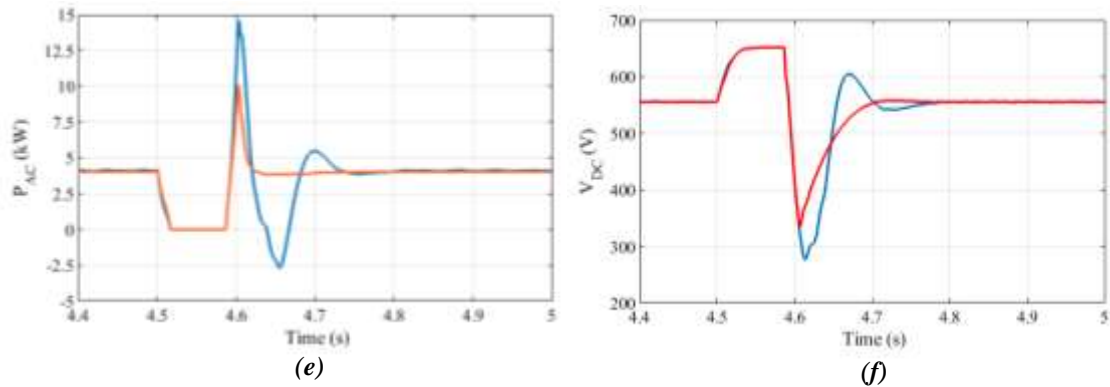

Figure 8. Responses of studied system when the three-phase fault happened at power grid: (a) Active power of the solar, (b) Voltage at DC-link of the solar PV, (c) Current in d-axis of the solar PV system, (d) Current in q-axis of the solar PV system, (e) Active power of the solar PV system, and (f) Voltage at DC-link

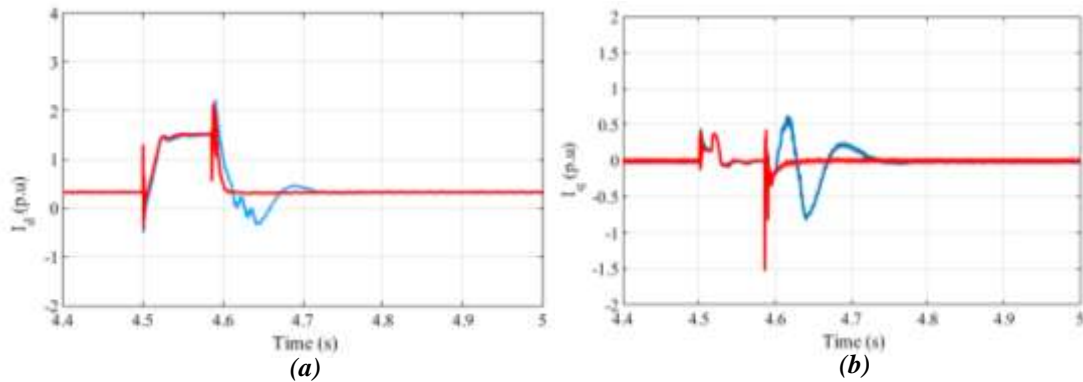

Figure 9. Responses of studied system when the three-phase short-circuit at the load: (a) Current in d-axis of the solar PV system, (b) a. Current in q-axis of the solar PV system

5. Conclusions

The stability improvement of a grid-connected rooftop solar PV system has been studied in this work. To obtain the maximum power, a P&O controller is designed for the PV system to track the MPP. The simulation results of the PV system addressed to three-phase short-circuits faults have proved the success of the proposed ANFIS controller in suppressing oscillations of the system. Based on the time-domain simulation results, it can say that the proposed ANFIS controller has better damping characteristics to enhance the transient responses of the system in terms of reducing overshoot and settling time of the grid-tie rooftop Solar PV inverter under severe operating conditions.

Acknowledgments

This work was supported by the Technology Program through the Ministry of Science and Technology of Vietnam under Grant CT2019.04.

REFERENCES

- [1] K. C. Rout and P. Kulkarni, "Design and Performance evaluation of Proposed 2 kW Solar PV Rooftop on Grid System in Odisha using PVsyst," 2020 IEEE International Students' Conference on Electrical, Electronics and Computer Science (SCEECS), 2020, pp. 1-6.
- [2] G. Coria, F. Penizzotto and R. Pringles, "Economic Analysis of Rooftop Solar PV Systems in Argentina," in IEEE Latin America Transactions, vol. 18, no. 01, pp. 32-42, January 2020.
- [3] Y. Sharma, B. K. Saxena, and S. Mishra, "Techno-Economic Analysis of Rooftop Solar PV System by Variation in PV Module Capacity," 2019 2nd International Conference on Power and Embedded Drive Control (ICPEDC), pp. 355-360, 2019.
- [4] H. Afghoul, D. Chikouche, F. Krim and A. Beddar, "A comparative study between sliding mode controller and P&O controller applied to MPPT," 2013 International Renewable and Sustainable Energy Conference (IRSEC), pp. 112-117, 2013.
- [5] C. Wang, M. Chen, X. Zhang and M. Gao, "An analog MPPT controller without multiplier for PV applications based on simplified P&O method," 2017 IEEE Energy Conversion Congress and Exposition (ECCE), pp. 2296-2300, 2017.
- [6] R. Khezri, A. Mahmoudi, and M. H. Haque, "Optimal Capacity of Solar PV and Battery Storage for Australian Grid-Connected Households," in IEEE Transactions on Industry Applications, vol. 56, no. 5, pp. 5319-5329, Sept.-Oct. 2020.
- [7] J. Windarta, D. Denis, S. Saptadi, J. S. Silaen, and D. A. Satrio, "Implementation and Testing of Rooftop Solar Power Plant with On-Grid System 1215 Wp Household Scale," 2020 7th International Conference on Information Technology, Computer, and Electrical Engineering (ICITACEE), pp. 294-299, 2020.

- [8] G. Coria, F. Penizzotto, and R. Pringles, "Economic analysis of photovoltaic projects: The Argentinian renewable generation policy for residential sectors", *Renewable Energy*, 2018.
- [9] S. Sebastian, E. A. S. Varghese, and E. J. Varghese, "Mitigation And Improvement Of Power Quality Using Shunt Series Switched Grid Tied Inverter (SSS-GTI)," 2021 7th International Conference on Electrical Energy Systems (ICEES), pp. 5-8, 2021.
- [10] K. Suresh and S. Balagopalan, "A three-stage buck in buck, boost in boost grid-tie inverter," 2018 International Conference on Power, Signals, Control and Computation (EPSCICON), pp. 1-6, 2018.
- [11] H. Ping, L. Dong, and Q. Xin, "Influence of Grid-connected Photovoltaic Systems on Power Quality," 2019 IEEE 2nd International Conference on Automation, Electronics and Electrical Engineering (AUTEEE), pp. 447-451, 2019.
- [12] B. Talbi, F. Krim, T. Rekioua, A. Laib, and H. Feroura, "Design and hardware validation of modified P&O algorithm by a fuzzy logic approach based on model predictive control for MPPT of PV systems", *Journal of Renewable and Sustainable Energy* 9, 043503, 2017.
- [13] L. Wang and D.-N. Truong, "Stability enhancement of a power system with a PMSG-based and a DFIG-based offshore wind farms using an SVC with an adaptive-network-based fuzzy inference system", *IEEE Transactions on Industrial Electronics*, vol. 60, no. 7, pp. 2799-2807, 2013.
- [14] V.-T. Bui, D.-N. Truong, "Improvement of ANFIS Controller for SVC Using PSO", In Huang YP., Wang WJ., Quoc H.A., Giang L.H., Hung NL. (eds) *Computational Intelligence Methods for Green Technology and Sustainable Development. GTSD 2020. Advances in Intelligent Systems and Computing*, vol 1284. Springer, Cham, 2021.
- [15] N.T. Truong, T.I. Seo, and S.D. Nguyen, "Bearing Fault Online Identification Based on ANFIS", *Int. J. Control Autom. Syst.* 19, 1703–1714, 2021.



Van-Phong Vu (Member, IEEE) received the B.S. degree from the Department of Automatic Control, Hanoi University of Sciences and Technology, Hanoi, Vietnam, in 2007, the M.S. degree from the Department of Electrical Engineering, Southern Taiwan University of Sciences and Technology, Tainan, Taiwan, in 2010, and the Ph.D. degree from the Department of Electrical Engineering, National Central University, Jhongli, Taiwan, in 2017. He is currently a Lecturer with the Ho Chi Minh City University of Technology and Education, Ho Chi Minh City. His research interests include the fuzzy systems, intelligent control, observer and controller design for the uncertain systems, polynomial systems, fault estimation, and large-scale systems.



An-Quoc Hoang, (PhD. at DaNang University, Vietnam) is working as Associate professor and Dean of Research Management and International Relation Office at Ho Chi Minh City University of Technology and Education. His research interests are Thermodynamic and Heat transfer and Renewable Energy. He has conducted many research projects on the applications of solar thermal energy and biomass gasification. He has published twenty-five research papers in various journals and conferences. He has also published three books in the field of thermal and refrigeration engineering.



Dinh-Nhon Truong (Member, IEEE) is an Associate professor in the Faculty of International Education at Hochiminh City University of Technology and Education, Vietnam. He received Ph.D. degree from the College of Electrical Engineering & Computer Science, National Cheng Kung University, Taiwan (2013). He is the author of many scientific publications in international journals and conferences. His research interests are grid-connected renewable energy, dynamic stability and FACTS devices.