

## Potential Applications of Natural Coagulants in Portable Filtration Device for Flood Zone Residents

**Hoang Thi Tuyet Nhung**

*Ho Chi Minh City University of Technology and Education, Vietnam*

Corresponding author. Email: [nhunghtt@hcmute.edu.vn](mailto:nhunghtt@hcmute.edu.vn)

### ARTICLE INFO

Received: 26/04/2023  
Revised: 31/05/2023  
Accepted: 02/06/2023  
Published: 28/06/2023

### KEYWORDS

Natural coagulant aids;  
Portable device;  
Avocado seed extract;  
Dragon fruit branch extract;  
Aluminum salt.

### ABSTRACT

Drinking water for residents who live in flood area is the concern of the government and environmental management. Using natural coagulants to transform flood water into potable water in order to reduce the number of chemical coagulants (aluminum salt) that have a negative impact on human health. The results of the flocculation procedure using agricultural residue extracts, dragon fruit branches (DFBE) and avocado seeds (ASE), did not meet the Vietnamese standard for the provision of potable water. Using DFBE and ASE as coagulation aides improves the flocculation efficacy of alum in high turbid water (150 to 175 NTU) and low turbid water (20 to 30 NTU). The ratio of ASE to Alum was determined to be 1/6 for high-turbidity water and 0.2 for low-turbidity water. The ratio of DFBE/Alum was determined to be greater than 1/3 for high turbidity water and less than 0.2 for low turbidity water. This ratio is also evaluated for a portable, simple, and user-friendly water filter that is suitable for flood-prone residents. Combining natural coagulation aides with Alum in water flocculation satisfies the Vietnamese standard with DFBE for sources with high turbidity and ASE for sources with low turbidity. This demonstrates the utility of natural coagulation aides derived from agricultural residues for water purification in flooded areas.

Doi: <https://doi.org/10.54644/jte.77.2023.1386>

Copyright © JTE. This is an open access article distributed under the terms and conditions of the [Creative Commons Attribution-NonCommercial 4.0 International License](https://creativecommons.org/licenses/by-nc/4.0/) which permits unrestricted use, distribution, and reproduction in any medium for non-commercial purpose, provided the original work is properly cited.

### 1. Introduction

Vietnam is currently afflicted by numerous devastations each year. After catastrophes in flood-prone areas, rivers, streams, ponds, and lakes are frequently contaminated with sewage waste, silt, and dead animals. Bacteria, viruses, and parasites can proliferate and flourish in contaminated water sources, resulting in the spread of pathogens. Numerous environmentalists are concerned about the availability of potable water during and after a natural disaster. Currently, numerous water purification methods are proposed. In the event of precipitation, rainwater runoff can be collected for heating and imbibing. If it does not rain, water is collected from a river, stream, pond, lake, or canal and then clarified and disinfected. There are a variety of methods, including the use of alum, Chloramin B, Aquatabs tablets, and simmering water... These techniques, however, require time and equipment for water collection, filtration, and disinfection.

To eliminate turbidity, including suspended substances and colloids, from untreated water, a flocculating agent must be added. In water remediation procedures, numerous flocculants and coagulants, including inorganic coagulants (aluminum salts, iron salts, etc.) and synthetic organic polymers, are commonly employed. Since aluminum ions are inexpensive, they are extensively used in water and effluent treatment processes around the world. Numerous investigations [1], [2] have demonstrated the effectiveness of these coagulants. Nonetheless, their disadvantages are readily apparent: the operation is expensive and has detrimental effects on human health and the environment. Aluminum exposure may contribute to the development of Alzheimer's disease, according to research [3]. In addition, aluminum is not biodegradable and must be disposed of as garbage. The production of neurotoxic and carcinogenic residues from synthetic polymers is simple [3]. Therefore, substance abuse also causes apprehension.

The development of natural coagulants and natural coagulation aids has become a pressing concern in recent years [4]. These natural coagulant aids are derived from microbial, animal, and plant cells. These coagulant aids are harmless to human health and biodegradable. In addition, natural coagulant aids generate biodegradable sediment that is 20-30% less than aluminum alum [5]. It is not novel to eradicate water turbidity using natural plant-based coagulants and aids. In tropical regions, natural coagulants/aids used in daily life have been employed for centuries as traditional flocculation methods [6], [7]. Numerous studies characterize other natural coagulants and coagulation aids, such as *Moringa oleifera* [7], [8], corn and maize seeds [9], legumes, and cactus seeds [10]. According to [11] research, the flocculation capacity of the grains of the yellow scorpion is comparable to that of alum. Under identical experimental conditions, Juferi Idris's research indicates that dragon fruit branches are more effective than ferrous alum as a coagulant [12].

Dragon fruit branches are a by-product of agricultural production in relatively large quantities because they are pruned quite often and are usually only used as fertilizer or discarded. However, numerous scientific studies have demonstrated that the components of dragon fruit branches can be used in water treatment technology. Moreover, according to a study conducted by Khodapanah N., dragon fruit branches are as effective as aluminum alum at removing water turbidity [13]. The mucilage and fibrous fibers found in plants are the two primary factors that contribute to their ability to remove turbidity [14], and since dragon fruit branches belong to the same cactus family, their inner tissue also contains this mucus. In addition, avocado seeds have been used for research in numerous disciplines, including medicine, where phytochemicals [15] and Methanolic substances extracted from avocados [16] have been investigated. According to research by Chivatá L. David published in 2018 [17], avocado seed extract is 80.45% effective at treating water turbidity.

In addition to coagulants or coagulant aids, residents of flood-prone areas need a simple, lightweight, and efficient water purification device during certain flooding events. Current methods are complicated because they require specific instructions, time to filtrate and then disinfect, and inadequate equipment during flood season. In this study, dragon fruit branch extract and avocado seed extract were used as coagulation aids to combine aluminum alum, which is initially practicable for a simple, energy-free, compact water purification system that is lightweight and portable enough for humans to use during the flood season.

## 2. Materials and Methods

### 2.1. Preparation of coagulants from dragon fruit branch and avocado seeds.

The dragon fruit (red flesh dragon fruit) branches come from a Binh Thuan farm. It was cleansed with water, cut into minuscule pieces, and desiccated at 40°C for three days. They would then be ground, milled, and sieved to produce a fine powder with a sieve size of 0.3 mm. When not in use, the powdered dragon fruit branch will be stored in a desiccator. The preparation of coagulant from avocado is the same as for dragon fruit branches after the avocado seed coat is removed.

1 g of powdered material (avocado seed or dragon fruit branch) was added in 100 ml of distilled water, and agitated at 350 rpm for 30 minutes. The solution was then centrifuged for 5 minutes at 250 rpm. Then, the coagulant solution was gathered for flocculation experiments by removing the extract layer from the surface. This solution is stored at 4 degrees Celsius.

The artificial water with an initial turbidity of between 150 and 175 NTU was prepared by using the standard turbidity solutions of hydrazine sulfate ( $\text{NH}_2\text{NH}_2\cdot\text{H}_2\text{SO}_4$ , China) and hexamethylenetetramine ( $\text{C}_6\text{H}_{12}\text{N}_4$ , China). 10g/L of hexamethylenetetramine and 10 g/L of hydrazine sulfate were stirred in 1 hour and then let stand for 24 h to allow for complete hydration of formazin to get the artificial turbid water with a standard turbidity solution of 4000 NTU. The actual river water with an initial turbidity of between 20 and 30 NTU was collected at branch of Dong Nai River, district 9.

### 2.2. Evaluation of the coagulation ability of the preparation material.

Using jar test assays, the optimal dosage of aluminum salt (alum) (China), avocado seed extract (ASE), and dragon fruit branch extract (DFBE) was determined for artificial water with an initial turbidity between 150 and 175 NTU.

In order to reduce the amount of alum required, ASE or DFBE was combined with alum to remove turbidity from water. The ratio of ASE/DFBE and alum concentration was analyzed to ensure compliance with the Vietnamese potable water supply standard (QCVN 02:2009/BYT). This ratio was determined using two different water sources, artificial water containing 150-175 NTU and river water containing 20-30 NTU.

The coagulant solution (alum and powder extract in varying proportions) was added to beakers containing 700 mL of water for the jar test experiments. The mixture was then agitated for 1 minute at 100 revolutions per minute, followed by 5 minutes of moderate stirring at 20 revolutions per minute. After 5 minutes of settling, the absorbance of the water's turbidity was measured at 450 nm. The pH of water was adjusted with NaOH 0.1N or H<sub>2</sub>SO<sub>4</sub> 0.1N solutions.

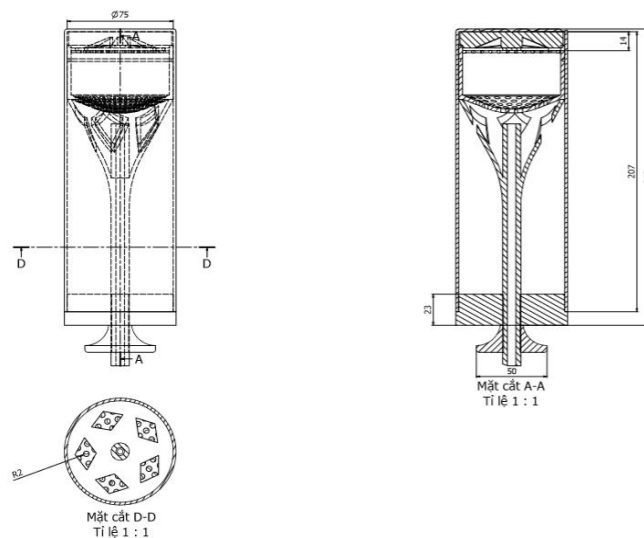
### 2.3. A portable filtration device

A glass container and a filter are the two primary components of the water filter device. The component of the filter affixed to the lid will be secured to the body of the container, and the piston mechanism will generate pressure so that purified water will rise to the top and sediment will settle to the bottom. Within the filter, there will be layers of filter cotton and activated carbon to remove residues and microorganisms. To consume the water, the user will use the straw located on the top of the container.

In this water filter, the optimal ratio of alum and ASE/DFBE as determined by the jar test experiments was utilized. The apparatus was vigorously shaken for 30 to 60 seconds after the addition of the coagulation solution mixture. Water with flocculants is allowed to rest for two minutes before being filtered using a piston and a filter layer.



**Figure 1.** 3D model of a drinking water device for flood-prone residents



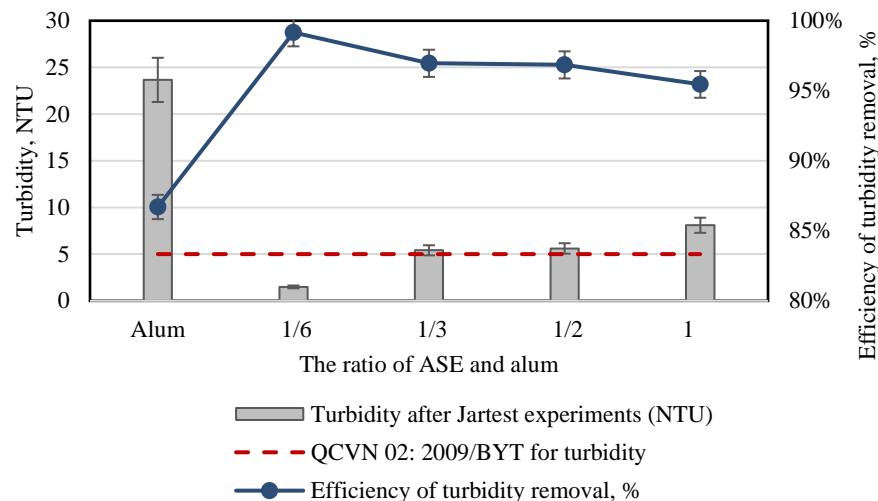
**Figure 2.** Design of a drinkable water device for inhabitants at risk of flooding

### 3. Results and Discussion

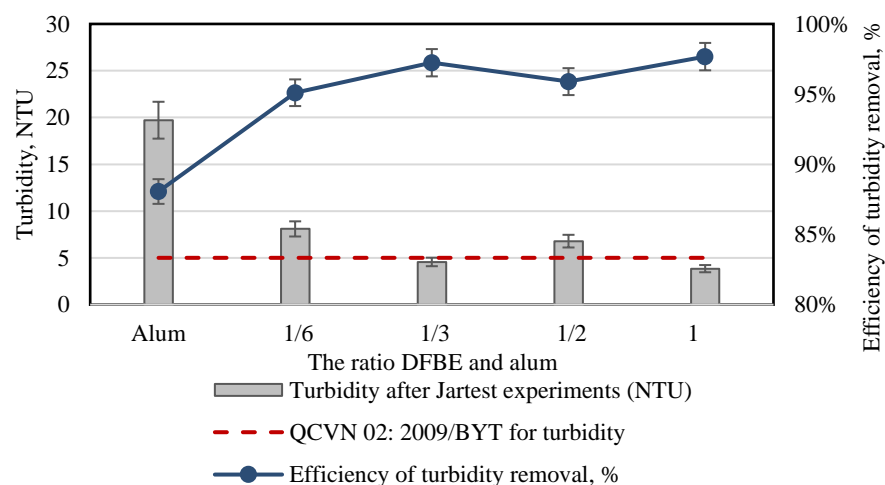
#### 3.1. Evaluation of the flocculation efficiency of avocado seed and dragon fruit branch extracts.

In an endeavor to reduce the quantity of alum used for the elimination of water turbidity, the flocculation ability of extracts prepared from agricultural wastes and the combination of these extracts with alum will be evaluated. The jar test investigations were conducted with 150-175 NTU initial turbidity artificial water and 20-30 NTU initial turbidity river water. Similar to the pH of natural water sources, the pH of the water sample was maintained between 6-6.5.

The optimum dosage of alum for artificial water was 29 mg/l with the outlet turbidity was 4.23 NTU (meeting turbidity standards for potable water). The same experiment was conducted with ASE and DFBE-derived coagulants. The dose of coagulant solution applied to the water source varied from 2.3 mg/L to 9.1 mg/L, and the results demonstrated that as the amount of coagulant increased, the turbidity treatment efficacy decreased. This may be owing to the ability of the coagulant extract to increase turbidity. This result did not meet the Vietnamese standard for potable water supply (QCVN 02:2009/BYT standard) because the treatment efficacy of ASE was only 82% (corresponding to a dose of 2.3 mg/L) and that of DFBE was only 79% (corresponding to a dose of 2.3 mg/L). In conclusion, ASE and DFBE are not activated in the flocculation process as coagulants. Experiment involving the use of ASE and DFBE as a coagulation aid.

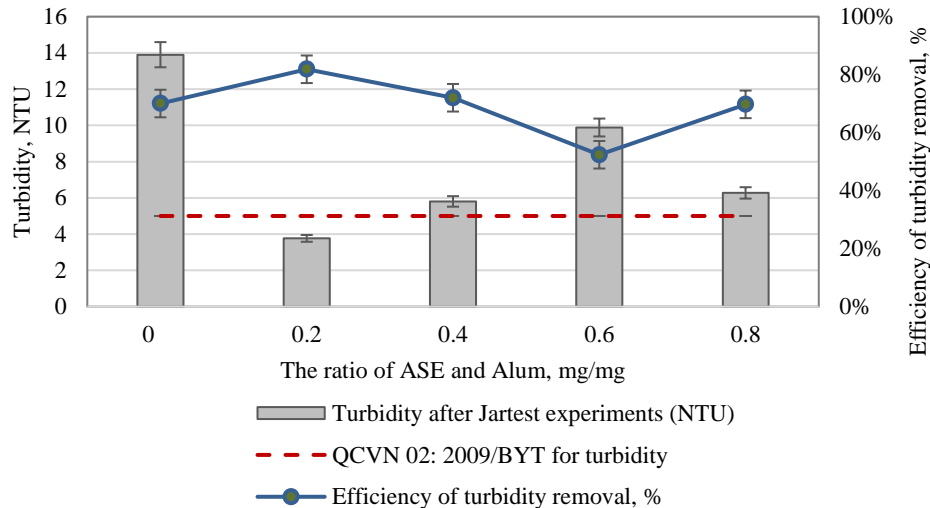


**Figure 3.** The turbidity treatment efficiency of the ASE as coagulation aids using artificial water with an initial turbidity of 150-170 NTU (the alum dosage is 29 mg/L)

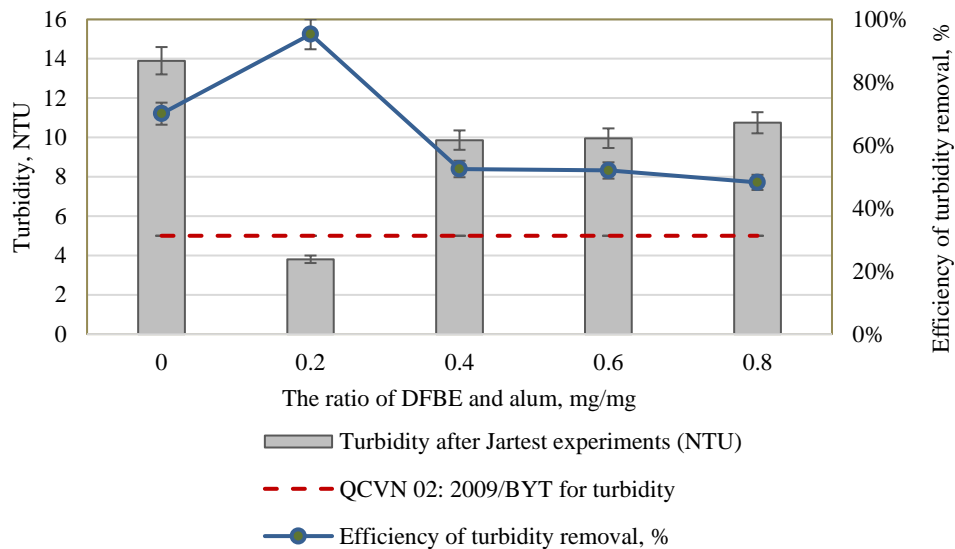


**Figure 4.** The turbidity treatment efficiency of the DFBE as coagulation aids using artificial water with an initial turbidity of 150-170 NTU (the alum dosage is 29 mg/L)

To minimize the quantity of alum used in the flocculation process, alum was combined with extracts from two different types of agricultural refuse at a concentration ratio of 1/6:1. The dosage used was 23 mg alum/L. The turbidity of the outlet exceeded the standards for potable water. Using ASE or DFBE as coagulant aids reduces the alum dosage from 29 to 23 mg/L. Figures 3 and 4 depict the consequences of combining alum with ASE and DFBE in varying proportions.



**Figure 5.** The turbidity treatment efficiency of the ASE as coagulation aids using artificial water with an initial turbidity of 20-30 NTU (the alum dosage is 7 mg/L)



**Figure 6.** The turbidity treatment efficiency of the DFBE as coagulation aids using artificial water with an initial turbidity of 20-30 NTU (the alum dosage is 7 mg/L)

With ASE as coagulation aids, alum's turbidity removal efficiency increases from 85.83% to over 95% (Figure 3). The ratio of 1/6 (ASE/alum) has the utmost efficiency; the outflow turbidity was 1.5NTU, which is significantly lower than the QCVN 02:2009/YT standard. The greater the ratio of ASE to Alum, the lesser the turbidity removal efficacy. The high concentration of ASE as a coagulation aid increases turbidity and Using DFBE as a coagulation aid reduces outlet turbidity to meet QCVN 02:2009/BYT requirements. To meet the standard, however, the dosage of DFBE is greater than that of ASE, the ratio of DFBE to alum being greater than 1/3 (Figure 4). The avocado seed and dragon fruit branch extract contains a high concentration of O-H functional groups from the phenolic compound Dopamine (3,4-dihydroxyphenylalanine), which has the same coagulant effect as tannin. When added to an alkaline solution (NaOH solvent), the O-H bonds in the extracts are disrupted, and the H<sup>+</sup> ion

interacts with the negative ions in water, enhancing coagulation efficacy [18]. In addition, the high molecular weight extracts provide additional sites for physical adhesion and chelation via hydrogen bonding to the particulates; consequently, when the extracts were used in conjunction with alum, turbid removal was enhanced due to increased chelation. [19]

The optimal dosage of alum for treating Dong Nai river water with an initial turbidity between 20 and 30 NTU was 10 mg/L, while the outflow turbidity was 0.5 NTU. 7 mg/L was equivalent to 14 NTU of outflow turbulence. Different ratios of ASE or DFBE were used as coagulation aides to reduce the outlet turbidity caused by a 7 mg/L alum dosage. inhibits alum flocculation.

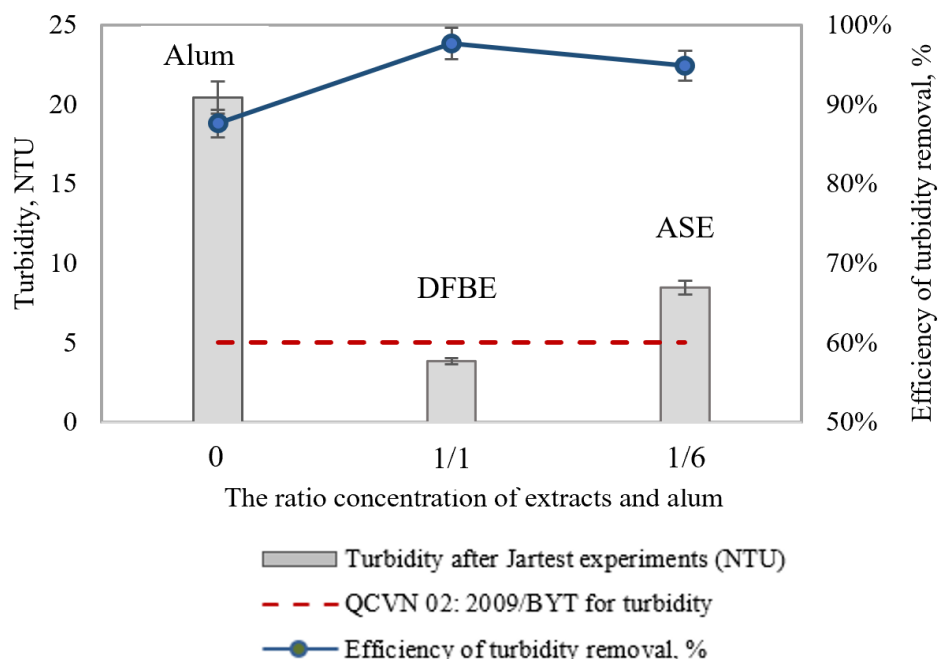
The ratio of coagulation aids to alum was less than 1 and the dosage of coagulation aids in high turbidity water met the standard. With low turbidity water, the ratio was altered from 0 to 0.8 (Figures 5 and 6). The concentration of coagulation aids increases the turbidity of treated water, and the lowest concentration of natural aides was the most effective. The absence of these natural aides prevents the treated water from meeting the standard, which is three times higher than their presence.

### 3.2. Evaluation of the filtration efficiency of a portable filter device.

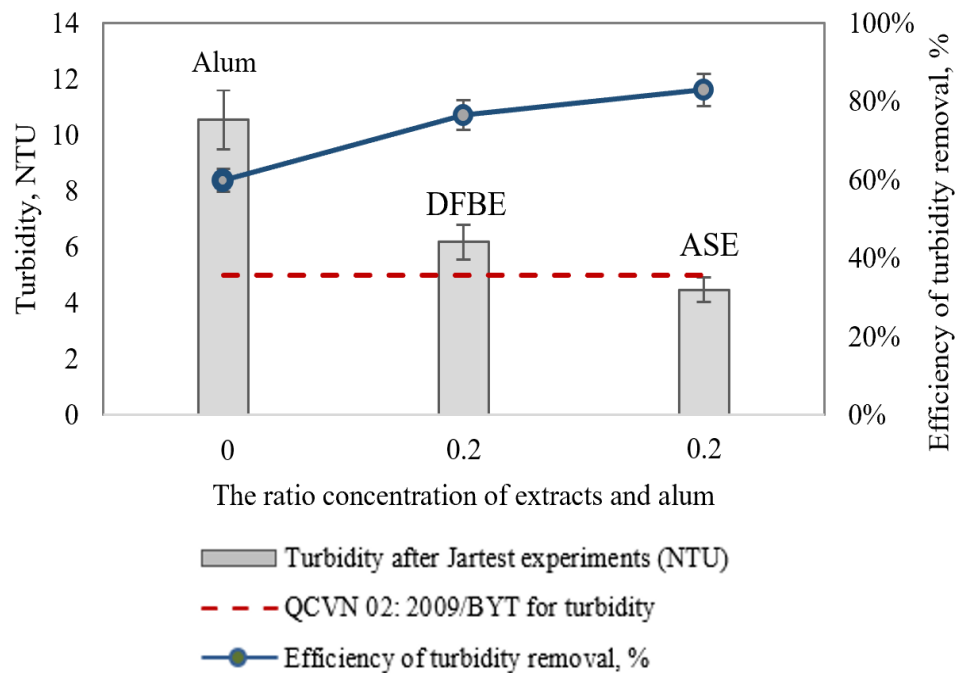
Preliminary assessment of the turbidity treatment efficiency of the portable filter device by shaking vigorously for 1 minute 30 seconds and then let it rest for 2 minutes. After flotation, water was pressed through the filter material by the piston. Figure 7 (artificial water) and Figure 8 (actual river water) illustrate the optimal ratio of aids and alum in portable filter device. Layers of filter cotton and activated carbon are incapable of removing minute particles, so the turbid efficiency of a portable filter device without coagulant is not remarkable.

In figure 7, artificial water with an initial turbidity between 150 and 160 NTU and alum concentration of 29 mg/L was selected. The turbidity treatment efficacy of the portable filter met the requirements of QCVN 02: 2009/BYT (turbidity 5 NTU) with a concentration ratio of 1:1 for DFBE and alum. The ASE-to-alum ratio of 1/6 does not meet the standard, despite the high efficacy observed in jar test experiments.

Actual river water with an initial turbidity of 20 to 30 NTU and alum concentration of 7 mg/L was selected for Figure 8. The outcomes of turbidity removal differ from those of artificial water. ASE is more effective than DFBE.



**Figure 7.** The turbidity treatment efficiency of the portable device using artificial water with an initial turbidity of 150-160 NTU (the fixed aluminum salt dosage is 29 mg/L)



**Figure 8.** The turbidity treatment efficiency of the portable device using actual river water with an initial turbidity of 20-30 NTU (the fixed aluminum salt dosage is 7 mg/L)



**Figure 9.** Water before and after filtration by portable device

#### 4. Conclusions

There is no assurance that extracts from dragon fruit branches and avocado seeds will effectively treat water on their own. In the meantime, aluminum salt, a long-used type of coagulant, has very high processing efficacy. Nevertheless, alum is believed to be hazardous to human health. The combination of dragon fruit branch extract and avocado seed extract with aluminum salt can therefore reduce or replace a portion of alum in the turbidity treatment process. The actual device's performance confirmed the preliminary evaluation of its capacity to manage two levels of turbidity. Normal river water purification (approximately 20 NTU turbidity) is suitable for avocado seed extract, whereas high turbidity (flood water) necessitates dragon fruit branch extract.

## REFERENCES

- [1] J. Edzwald, "Coagulation in Drinking Water Treatment: Particles, Organics and Coagulants," *Water Science and Technology*, vol. 27, pp. 21-35, 1993.
- [2] M. Kang, T. Kamei, and Y. Magara, "Comparing polyaluminum chloride and ferric chloride for antimony removal," *Water Research*, vol. 37, no. 17, pp. 4171-4179, 2003.
- [3] J. F. Lee, P. M. Liao, D. H. Seng, and P. T. Wen, "Behavior of organic polymers in drinking water purification," *Chemosphere*, vol. 37, no. 6, pp. 1045-1061, 1998.
- [4] M. Y. D. Alazaiza *et al.*, "Application of Natural Coagulants for Pharmaceutical Removal from Water and Wastewater: A Review," *Water*, vol. 14, no. 2, p. 140, 2022, doi: 10.3390/w14020140.
- [5] K. S. Narasiah, A. Vogel, and N. N. Kramadhathi, "Coagulation of turbid waters using Moringa oleifera seeds from two distinct sources," *Water Supply*, vol. 2, no. 5-6, pp. 83-88, 2002.
- [6] L. J. Fuglie, *The Miracle Tree - The Multiple Attributes of Moringa*, Church World Service, 2001.
- [7] W. M. Desta and M. E. Bote, "Wastewater treatment using a natural coagulant (Moringa oleifera seeds): optimization through response surface methodology," *Heliyon*, vol. 7, no. 11, p. e08451, 2021.
- [8] M. K. Karnena, M. Konni, B. K. Dwarapureddi, and V. Saritha, "Blend of natural coagulants as a sustainable solution for challenges of pollution from aquaculture wastewater," *Applied Water Science*, vol. 12, no. 3, p. 47, 2022.
- [9] P. K. Raghuvanshi, M. Mandloi, A. J. Sharma, H. S. Malviya, and S. Chaudhari, "Improving Filtrate Quality Using Agrobased Materials as Coagulant Aid," *Water Quality Research Journal of Canada*, vol. 37, pp. 745-756, 2002.
- [10] A. Diaz *et al.*, "A preliminary evaluation of turbidity removal by natural coagulants indigenous to Venezuela," *Process Biochemistry*, vol. 35, no. 3, pp. 391-395, 1999.
- [11] A. Ndabigengesere, K. S. Narasiah, and B. G. Talbot, "Active agents and mechanism of coagulation of turbid waters using Moringa oleifera," *Water Research*, vol. 29, no. 2, pp. 703-710, 1995.
- [12] J. Idris *et al.*, "Dragon Fruit Foliage Plant-Based Coagulant for Treatment of Concentrated Latex Effluent: Comparison of Treatment with Ferric Sulfate," *Journal of Chemistry*, vol. 2013, pp. 1-7, 2013.
- [13] N. Khodapanah, "Potential of using bio-coagulants indigenous to Malaysia for surface water clarification," *Research journal of Chemistry and Environment*, vol. 17, pp. 70-75, 2013.
- [14] L. Qi *et al.*, "Influence of Mangosteen Pericarp (mp) in Coagulation Treatment and Membrane Fouling," *Chemical Engineering Transactions*, vol. 56, p. 6, 2017.
- [15] D. Dabas, R. M. Shegog, G. R. Ziegler, and J. Lambert, "Avocado (Persea americana) Seed as a Source of Bioactive Phytochemicals," *Current pharmaceutical design*, vol. 19, 2013, doi: 10.2174/1381612811319340007.
- [16] E. Neboh, S. Ufelle, and T. I. Anele, "Effect Of Methanolic Seed Extract Of Persea americana (Avocado Pear) On Prothrombin Time And Activated Partial Thromboplastin Time In Mice," *Journal of Experimental Research*, vol. 3, pp. 92-96, 2015.
- [17] C. L. David, C. Celis, L. Pombo, and R. A. Oscar, "The Coagulant Activity of the Seeds of Psidium guajava L. and the Episperm of Persea americana Mill. in Samples of Water from the Bogotá River (Chocontá-Villapinzón)," *Indian Journal of Science and Technology*, vol. 11, 2018, doi: 10.17485/ijst/2018/v11i21/123195.
- [18] J.-R. Jeon *et al.*, "Use of grape seed and its natural polyphenol extracts as a natural organic coagulant for removal of cationic dyes," *Chemosphere*, vol. 77, no. 8, pp. 1090-1098, 2009.
- [19] R. Sanghi, B. Bhattacharya, A. Dixit, and V. Singh, "Ipomoea dasysperma seed gum: An effective natural coagulant for the decolorization of textile dye solutions," *Journal of Environmental Management*, vol. 81, no. 1, pp. 36-41, 2006.



**Hoang Thi Tuyet Nhung.** She was born in Ho Chi Minh city, Vietnam. She got her Bachelor and Master degree in Environmental technology at Ho Chi Minh City University of Technology in 2005 and 2008, respectively. Her PhD degree was at Ho Chi Minh city Institute for Environment and Resources in 2018. She is a Full-time Lecturer in Environmental Technology at Faculty of Chemical & Food Technology, Ho Chi Minh City University of Technology and Education. She has studied to develop materials for applications in water and wastewater treatment. Email: [nhunghtt@hcmute.edu.vn](mailto:nhunghtt@hcmute.edu.vn).