

A Mathematical Model for a Hybrid Ignition System

Am Quoc Do

Ho Chi Minh City University of Technology and Education, Vietnam

*Corresponding author. Email: amdq@hcmute.edu.vn

ARTICLE INFO

Received: 05/06/2023
Revised: 20/07/2023
Accepted: 24/07/2023
Published: 28/10/2023

ABSTRACT

In the operation of a car's ignition system, the primary ignition coil is responsible for generating a high voltage that typically ranges from around 100V to 300V. However, this self-induced electromotive force (emf) can lead to certain negative effects such as switch breakdown, inductive noise, and secondary voltage drop. This article introduces a novel hybrid ignition system designed for a 4-cylinder engine. This innovative system is a combination of capacitive discharge ignition system (CDI) and induction discharge ignition (IDI) system. The excess electromagnetic force energy (emf) generated during the induction ignition stage will be used in the capacitive ignition. Thereby contributing to limiting the negative effects as mentioned. Forming and solving the mathematical model for the hybrid ignition system mentioned above enables us to analyze the transient responses of the primary current (i_l) and primary voltage (V_l). These instantaneous responses are crucial in understanding the behavior of the composite ignition circuit and calculating key parameters such as ignition energy during the inductive and capacitive ignition stages, as well as the magnitude of the maximum secondary voltage (V_{2m}). Furthermore, the article also presents experimental results from the hybrid ignition system to complement the theoretical analysis.

KEYWORDS

Hybrid ignition system;
Self-induced electromotive force;
Accumulated energy;
Capacitive ignition;
Induction ignition.

Doi: <https://doi.org/10.54644/jte.79.2023.1420>

Copyright © JTE. This is an open access article distributed under the terms and conditions of the [Creative Commons Attribution-NonCommercial 4.0 International License](https://creativecommons.org/licenses/by-nc/4.0/) which permits unrestricted use, distribution, and reproduction in any medium for non-commercial purpose, provided the original work is properly cited.

1. Introduction

Earlier studies on hybrid ignition systems, which combine capacitive and inductive ignition methods, primarily focused on two main directions: extending the duration of spark time [1]-[6] or increasing the quantity of sparks generated on the spark plug [7]. However, the research direction of utilizing a portion of the inductive energy from the inductive ignition phase for the capacitive ignition phase has not been mentioned in previous studies.

The proposed hybrid ignition system illustrated in Figure 1, comprises two operational stages: the induction ignition stage and the capacitive ignition stage. In the induction ignition stage, the engine electronic control unit (ECU) regulates the ignition process for cylinders 1, 2, and 3 (induction ignition) using signals IGT1, IGT2, and IGT3, respectively. A portion of the inductive energy generated by ignition coils 1, 2, and 3 is stored in capacitors C1, C2, and C3.

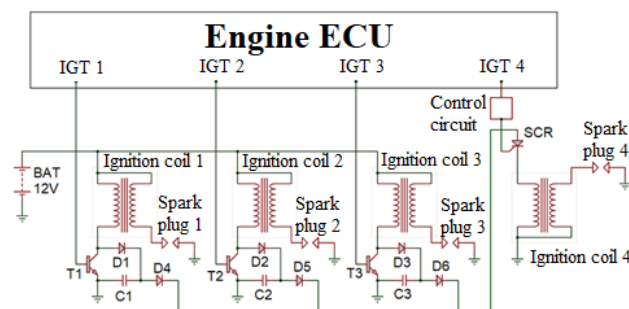

Figure 1. Schematic illustration of the hybrid ignition system for a four-cylinder engine

In the capacitive ignition stage, corresponding to cylinder 4, the IGT4 signal activates the SCR (Silicon Controlled Rectifier), triggering its opening. The energy stored in capacitors C1, C2, and C3 is discharged into the primary coil (of the ignition coil 4), generating a spark in cylinder 4.

The parameters of hybrid ignition system (IDI stage) are presented in the Table 1.

Table 1. The parameters of the hybrid ignition system- IDI stage

| No. | Parameter | Symbol | Unit | Value |
|-----|--|----------|----------|----------------|
| 1 | Energy accumulation time | t_d | s | 5.10^{-3} |
| 2 | Capacitance | C_1 | F | 1.10^{-6} |
| 3 | Leakage resistance of capacitor C ₁ | r | Ω | 10^{-6} |
| 4 | Resistance | R | Ω | 1,5 |
| 5 | Self-inductance | L_1 | H | $1,25.10^{-3}$ |
| 6 | Supplied voltage | V | V | 12,6 |
| 7 | Coil's transformer ratio | K_{bb} | | 100 |

2. Inductive discharge ignition stage

The inductive ignition stage is subdivided into two stages: the energy accumulation stage and the primary current interrupting stage.

2.1. Energy accumulating stage

Figure 2 illustrates the proposed computational model for the energy accumulation stage of the hybrid ignition system.

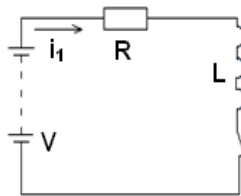

Figure 2. Computational model of the hybrid ignition system - energy accumulating stage

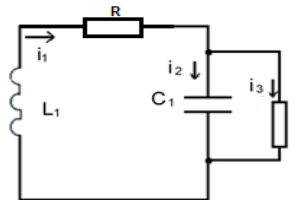

Figure 3. Computational model of the hybrid ignition system -primary current cut-off stage

By applying Kirchhoff's law to the computational model presented in Figure 2, we obtain the corresponding differential equation [8].

$$V = i_1 R + L_1 \frac{di_1}{dt} \quad (1)$$

With:

R : resistance of the primary circuit: ($R = R_f + R_l$)

R_f : additional resistance of the system, the power transistor resistance when saturated and the conductor resistance.

R_l : primary coil resistance of the ignition coils.

L_1 : inductance of primary coil.

i_1 : primary current in the period while power transistor is switched on

Solving equation (1), we obtain:

$$i_1 = \frac{V}{R} (1 - e^{-\frac{R}{L_1} t_d}) \quad (2)$$

t_d : time for accumulating energy.

2.2. The primary current interrupting stage.

Applying Kirchhoff's law to the above diagram (Figure 3) we have:

$$\begin{cases} -L_1 \frac{di_1}{dt} = i_1(t)R + i_3(t)r \\ i_1(t) = i_2(t) + i_3(t) \\ ri_3(t) = \frac{1}{C_1} \int i_2(t)dt \end{cases} \quad (3)$$

Laplace transformation of these equations (3)

$$i_1(t) = 0.7[ae^{5xt} \cos(yt) + ze^{5xt} \sin(yt)] \quad (4)$$

$$\text{Put } \begin{cases} x = -\frac{c}{2} \\ y = \sqrt{d - \frac{c^2}{4}} \\ z = \frac{b - \frac{ac}{2}}{\sqrt{d - \frac{c^2}{4}}} \end{cases} \quad \text{and} \quad \begin{cases} a = I_0 \\ b = \frac{I_0}{C_1 r} \\ c = \frac{L_1 + RC_1 r}{L_1 C_1 r} \\ d = \frac{R+r}{L_1 C_1 r} \end{cases} \quad (5)$$

Using:

- R : total resistance of primary circuit (Ω)
- r : capacitor leakage resistance $r = 10^6 \Omega$ [9].
- i_1 : the current goes through R (A).
- i_2 : the current goes through capacitor C_1 (A).
- i_3 : leaking current in capacitor C_1 (A).
- L_1 : primary coil's inductance (H).
- C_1 : condenser's capacity (F).

Electromotive force on the primary coil when the power transistor turned off $V_1(t)$:

$$V_1(t) = -L_1 \frac{di_1}{dt} \quad (6)$$

$$V_1(t) = -L_1 \frac{di_1}{dt} = -0,7L_1[(5xa + zy)e^{5xt} \cos(yt) + (5xz - ay)e^{5xt} \sin(yt)] \quad (7)$$

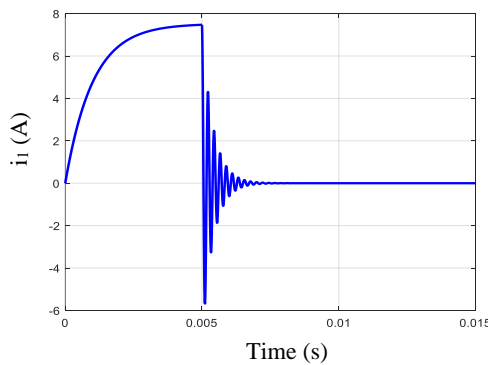

Figure 4. Simulation result of the primary current $i_1(t)$ - IDI stage.

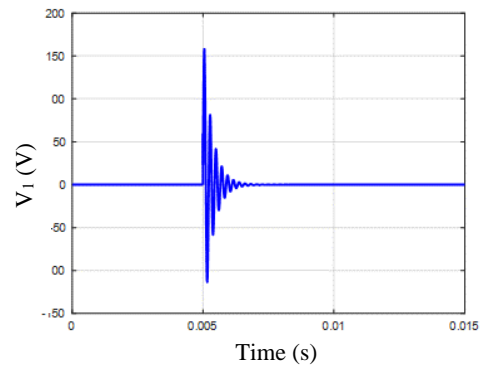

Figure 5. Simulation result of the emf $V_1(t)$ - IDI stage

Figure 4, Figure 5, and Figure 6 display simulation and experimental results concerning the primary current and inductance electromotive force (emf). The graphs demonstrate a strong agreement between the calculated responses and the experimental findings.

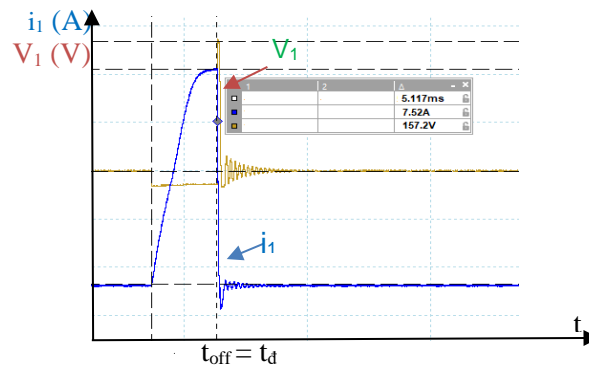

Figure 6. The experimental results of the primary current $i_{1(t)}$ and self-induced emf $V_1(t)$ - IDI stage

3. Effect of capacitance C_1 on hybrid ignition

Capacitors serve as dampers in a system, which means that increasing the capacitance of capacitor C_1 will result in a reduction of the peak value of the primary voltage V_{1m} (shown in Figure 7)

Impact of capacitance C_1 on capacitive ignition energy W_{dd} and inductive ignition energy W_{dc}

Because capacitor C_1 is connected to primary ignition coil (show Figure 1), when i_1 is interrupted, the accumulated energy on the primary coil will be divided as follows:

$$W_L = W_{dc} + W_{dd} \quad (8)$$

With W_L : represents the stored energy in the primary coil [10].

$$W_L = L_1 i_1^2 / 2 \quad (9)$$

W_{dd} : stored energy in capacitor [11].

$$W_{dd} = C_1 V_{1m}^2 / 2 \quad (10)$$

W_{dc} : energy for inductive ignition

$$W_{dc} = W_L - W_{dd} \quad (11)$$

By utilizing the data provided in Table 1, we can perform calculations to determine W_L , W_{dd} , and W_{dc} . These values will be further elaborated upon in Figure 8.

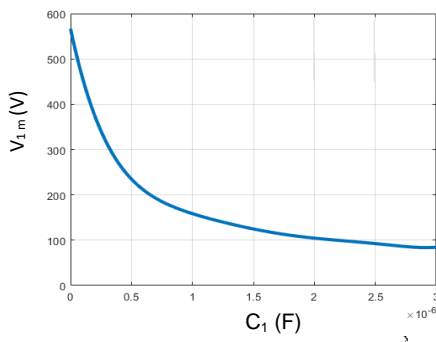

Figure 7. Relationship between peak voltage V_{1m} and condenser's capacity C_1

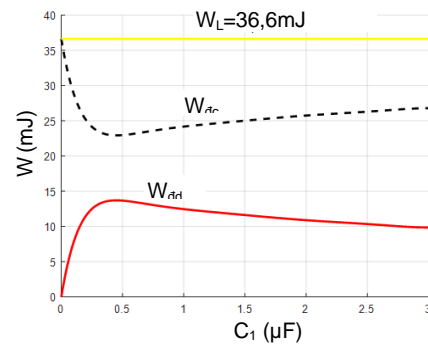

Figure 8. Relationship between W_L , W_{dd} , W_{dc} and condenser's capacity C_1

To ensure stable engine operation, the ignition system needs to fulfill the following requirements simultaneously:

The maximum magnitude of the secondary voltage, V_{2m} , should be greater than $V_{lim} = 15\text{kV}$ [12] to guarantee the occurrence of sparks at the spark plugs.

The energy required to ignite an air/fuel mixture, considering both the CDI and IDI ignition stages, must meet a minimum threshold of $W_{lim} = 15\text{mJ}$ [13].

In the mentioned hybrid ignition system, a $1\mu\text{F}$ capacitor (C_1) is utilized. With this capacitance, the energy calculated for inductive ignition is $W_{dc} = 23.45\text{mJ}$, while the energy accumulated in the three capacitors for capacitive ignition is calculated as $3W_{dd} = 39.45\text{mJ}$ (Figure 8). Hence, the ignition energy for both phases exceeds the desired threshold of W_{lim} . Additionally, the peak voltage V_{2m} (calculated as $V_{2m} = V_{1m} \cdot K_{bb}$) is valued at 18kV , surpasses the limit of $V_{lim} = 15\text{kV}$ (Figure 7).

4. Capacitive discharge ignition stage (CDI stage)

Determine equations of primary current $i_d(t)$ and self-induced emf $e_d(t)$.

After the Inductive discharge ignition (IDI) stage, a portion of the energy in ignition coils 1, 2, and 3 will be sequentially stored in capacitors C1, C2, and C3 (as depicted in Figure 1). The energy stored in these capacitors will then be elevated to the level of charge Q_0 .

Utilizing the R-L-C model for calculations, as illustrated in Figure 9, we consider the following parameters:

C_d : represents the equivalent capacitor of C1, C2, and C3, with a value of $3\mu\text{F}$.

S : denotes the switch, which represents the SCR.

L_d : signifies the self-inductance of the primary coil.

R_d : represents the equivalent resistance of the primary circuit.

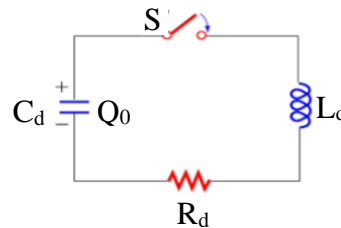

Figure 9. Computational model of the hybrid ignition system – capacitive ignition stage

Based on the computational model of the capacitor discharge ignition (CDI) stage as shown in Figure 9, we can construct the energy balance equation for the circuit.

$$L_d \frac{d^2Q}{dt^2} + R_d \frac{dQ}{dt} + \frac{Q}{C_d} = 0 \quad (12)$$

With the initial condition $Q(t=0) = Q_0$

$$\text{Therefore: } i_d(t) = Q_0 \omega' e^{-\gamma t} [\sin \omega' t + \left(\frac{\gamma}{\omega'}\right) \cos(\omega' t)] \quad (13)$$

$$\text{Where: } \gamma = \frac{R_d}{2L_d} \text{ and } \omega' = \sqrt{\omega_0^2 - \gamma^2} = \sqrt{\frac{1}{L_d C_d} - \left(\frac{R_d}{2L_d}\right)^2} \text{ with } \omega_0 = \frac{1}{\sqrt{L_d C_d}} \quad (14)$$

Develop primary circuit's self-induced emf equation $e_d(t)$

The following equation represents the self-induced electromotive force (emf) in the primary circuit:

$$e_d(t) = -L_d \frac{di_d(t)}{dt} \quad (15)$$

Proceeding the derivative of equation (14)

$$e_d(t) = L_d \cdot Q_0 \omega' e^{-\gamma t} \left[\left(\omega' - \frac{\gamma^2}{\omega'}\right) \cos \omega' t - 2\gamma \sin \omega' t \right] \quad (16)$$

The parameters of hybrid ignition system (CDI stage) are presented in the Table 2.

Table 2. The parameters of the hybrid ignition system- CDI stage

| No | Parameter | Symbol | Unit | Value |
|----|--|--------|---------------|-------|
| 1 | Total resistance of the capacitive ignition circuit | R_d | Ω | 0,5 |
| 2 | Inductance of the primary coil | L_d | mH | 0,2 |
| 3 | Capacitance of the capacitor (3 capacitors $1\mu\text{F}$ in parallel) | C_d | μF | 3 |

Simulation and experimental results, as shown in Figures 10 and 12, indicate a consistent growth pattern of primary current and self induced (emf) on the primary coil of the ignition coil. [14]

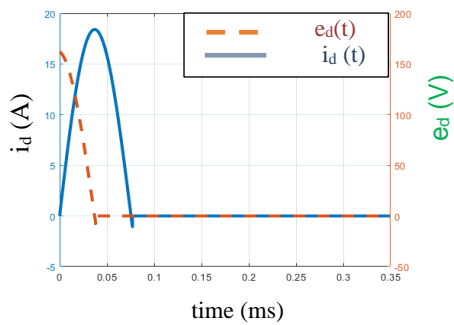

Figure 10. Simulation result of the primary current $i_d(t)$ and self induced emf $e_d(t)$ - CDI stage.

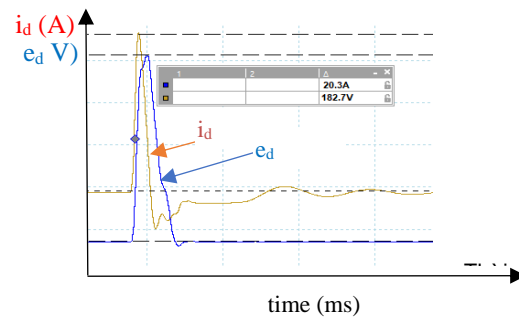

Fig 11. Primary current $i_d(t)$ and self-induced emf $e_d(t)$ - CDI stage in experiment

5. Investigation of electromotive force on the hybrid ignition system

The hybrid ignition system is designed - manufactured according to the descriptions in the above sections, when arranging the system's operation on the TOYOTA 1NZ-FE engine (engine speed: 6000 RPM). The performance result of the proposed hybrid ignition system is illustrated in Figure 12.

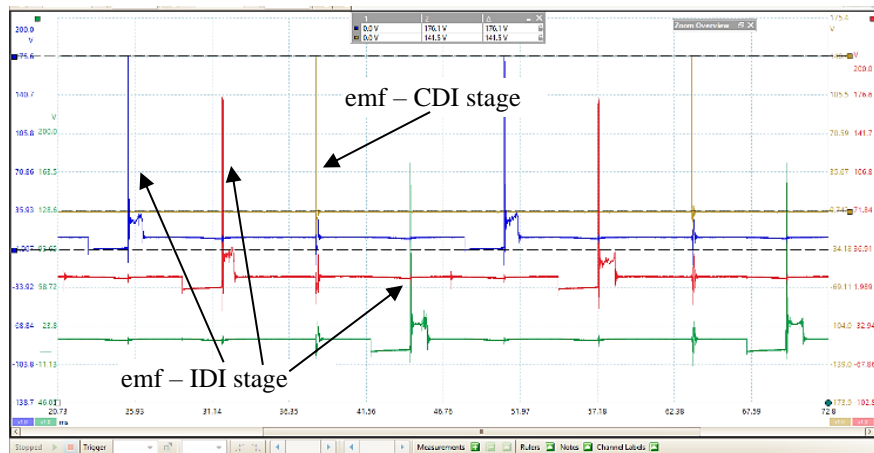

Figure 12. Electromotive force (emf) on the hybrid ignition system in experiment

Based on the experimental result, it can be observed that for every three activations of inductive ignition, the hybrid ignition system will perform one capacitive ignition. The results show that the mixed ignition system works stably, without any problem of misfire during operation.

6. Discussion

When constructing a mathematical model, the focus is on determining the primary current $i_1(t)$ and the electromotive force (emf) $V_1(t)$ without taking into account the secondary circuit, particularly the resistance losses in the secondary circuit.

In fact, when the voltage on the secondary circuit V_{2m} spikes from 0 to the breakdown voltage V_{brd} , spark will appear at the spark plug gap. During sparking, the spark plug gap resistance drops sharply, allowing the formation of a secondary current i_2 that discharges through the spark plug gap in the form of plasma, igniting the mixture. As a consequence of the energy transfer, the energy accumulated in the primary circuit of the ignition coils is converted into heat and plasma on the secondary side. Consequently, the primary energy rapidly decreases, leading to a reduction in the maximum value of the inductance (V_{Im}).

In addition, when a spark occurs, energy in the system is also dissipated faster due to the losses on the secondary circuit including: magnetic flux loss and heat loss.

Given these reasons, it becomes evident that the proposed mathematical model for the hybrid ignition system requires adjustments based on experimental observations and data. By incorporating these corrections, the model can more accurately capture the behavior of the system.

7. Conclusions

The article proposed a method for recovering a portion of the inductive energy from the primary coil of the ignition transformer. This method aims to reduce the energy consumption of the ignition system, as well as the overall energy usage of the engine. Additionally, by implementing this method, it is anticipated to contribute towards reducing emissions released into the environment.

By utilizing the provided parameters of the ignition system, the proposed mathematical model facilitates the determination of the required condenser's capacity responsible for storing a portion of the inductive energy. This ensures the ignition energy requirements for both the inductive ignition and capacitive ignition stages, while simultaneously fulfilling the energy-saving objectives of the system.

Acknowledgments

This work belongs to the project grant No: T2022-102 funded by Ho Chi Minh City University of Technology and Education, Vietnam.

REFERENCES

- [1] M. E. Gerry, "Inductive-capacitive cyclic charge-discharge ignition system," U.S. Patent 4288723, 1981.
- [2] M. J. French and M. J. Edwards, "Hybrid ignition circuit for an internal combustion engine," U.S. Patent 5806504, 1998.
- [3] J. M. Lepley, "Capacitive discharge ignition system with extended duration spark," U.S. Patent 6701904B2, 2004.
- [4] A. Simakaukas, "Hybrid Ignition system with variable spark duration for spark ignition engine," in *The 8th International conference*, 2013, p. 225.
- [5] M. E. Gerry, "Inductive-capacitive modulated ignition system," U.S. Patent 4291661, Aug. 13, 1979.
- [6] V. Heise, M. Loenarz, and F. Lorenz, "Ignition system," U.S. Patent 9.399.979 B2, Jul. 26, 2016.
- [7] M. Zheng, S. Yu, and J. Tjong, "High Energy Multipole Distribution Spark Ignition System," in *Ignition Systems for Gasoline Engines-3rd International Conference*, Berlin, Germany, Nov. 2016, p. 110.
- [8] D. V. Dung, *Electric Motors and Motor Control*, VNUHCM Publishing House (in Vietnamese), 2013, pp. 122-184.
- [9] *Capacitor Leakage Measurements Using a Model 6517A Electrometer*, Keithley Instruments Inc., Ohio, USA, 2001. [Online]. Available: http://www.tek.com/sites/tek.com/files/media/document/resources/Capacitor_Leakage_AN.pdf.
- [10] S. B. Liao, P. Dourmashkin, and J. Belcher, Inductance and Magnetic Energy, MIT 8.02 Course Notes, Chapter 11, pp. 6-11, 2011.
- [11] S. B. Liao, P. Dourmashkin, and J. Belcher, Inductance and Magnetic Energy, MIT 8.02 Course Notes, Chapter 5, pp. 13, 2011.
- [12] V. A. W. Hiller, *Fundamentals of automotive electronics*, 2nd ed., UK: Stanley Thornes Ltd, 1996, p. 196.
- [13] K. Reif, *Gasoline engine management system and components*, Springer Vieweg, 2015, p. 157.
- [14] D. V. Dung, D. Q. Am, and N. T. Ngoc, "Analysis of the Capacitive Ignition Process in a Hybrid Ignition System of Capacitive-Inductive Mixture," (in Vietnamese), *Journal of Technical Education Science*, no. 57, p. 65, 2020.



Do Quoc Am completed his Bachelor of Engineering degree from the Faculty of Vehicle and Energy Engineering at Ho Chi Minh City University of Technology and Education in 1990. He pursued further studies at the same university and received a master's degree in mechanical engineering in 2002. Continuing his academic journey, he successfully obtained a doctorate in mechanical engineering in 2021. Currently, Do Quoc Am serves as a senior lecturer at the Faculty of Vehicle and Energy Engineering at Ho Chi Minh City University of Technology and Education. His professional focus revolves around researching and enhancing efficiency in SI (Spark Ignition) engines, specializing in areas like ignition systems, improving fuel consumption, and reducing emissions in internal combustion engines.