

**RESEARCH PROPOSAL FOR AUTOMATION OF MEASURING  
THE STEERING WHEEL FREE ANGLE****NGHIÊN CỨU ĐỀ XUẤT PHƯƠNG ÁN TỰ ĐỘNG HÓA  
QUÁ TRÌNH ĐO ĐỘ RƠ VÔ LĂNG****Do Van Dung<sup>1</sup>, Le Quang Vu<sup>1</sup>, Ho Minh Dat<sup>2</sup>**<sup>1</sup>*Ho Chi Minh City University of Technology and Education, Vietnam*<sup>2</sup>*ISUZU VIETNAM CO., LTD, Vietnam**Received 17/03/2018, Peer reviewed 27/03/2018, Accepted for publication 06/4/2018***ABSTRACT**

*The steering system assumes the task of changing the direction of motion of the vehicle according to the driver's control. It would be dangerous if the driver cannot control the direction of the car as desired, this may result in a collision with another vehicle or inability to avoid obstacles on the road. Therefore, the inspection of the steering system is very important in the maintenance and repair activity, helping to detect the damage soon when it is loose. Because of this importance, the inspection of the steering wheel free play is one of the mandatory registration items in the vehicle registration process. However, the current method of measuring free play at the registries is completely manual, it does not accurately reflect the measurement results of the steering wheel free play. Therefore, this article presents the result of the research proposal for automation of the process of determining the steering wheel free play in the vehicle registration process. For the purpose of bringing automated devices into the registration process in order to increase accuracy, save time and minimize the human subjective factors. Initial research results have provided a feasible solution within the framework of the permissible technique. The research proposal was successfully tested on the current vehicle. Although it is just the beginning of test and research, the success of the research promises to open up a new process to solve some of the shortcomings of the current vehicle registration.*

**Keywords:** *vehicle inspection; the steering wheel free play; registration process; steering system diagnosis; automation in the registry.*

**TÓM TẮT**

*Hệ thống lái đảm nhận nhiệm vụ chuyển đổi hướng chuyển động của xe theo sự điều khiển của tài xế. Sẽ rất nguy hiểm nếu như khi tài xế đánh lái mà xe không chuyển hướng theo ý muốn, điều này có thể dẫn đến tai nạn va chạm với xe khác hoặc không thể tránh được các chướng ngại vật trên đường. Do đó việc kiểm tra hệ thống lái rất được quan tâm trong công tác bảo dưỡng sửa chữa, giúp sớm nhận ra các hư hỏng khi nó bị rơ lỏng. Vì sự quan trọng này nên việc kiểm tra độ rơ vô lăng lái là một trong những hạng mục đăng kiểm bắt buộc trong quy trình đăng kiểm xe cơ giới. Tuy nhiên hiện tại việc kiểm tra này còn thực hiện một cách thủ công chưa phản ánh chính xác kết quả của độ rơ. Vì vậy bài báo này trình bày kết quả nghiên cứu đề xuất phương án tự động hóa quá trình xác định độ rơ vô lăng trong quy trình đăng kiểm xe cơ giới. Với mục đích đưa các thiết bị tự động vào quá trình đăng kiểm thay thế cho việc thực hiện thủ công trước đây nhằm tăng độ chính xác, tiết kiệm thời gian và giảm thiểu yếu tố chủ quan của con người. Kết quả nghiên cứu bước đầu đã đưa ra được phương án khả thi trong khuôn khổ cơ sở kỹ thuật cho phép. Phương án đề xuất được thử nghiệm thành công trên xe hiện hành. Mặc dù đây chỉ là bước đầu nghiên cứu và thử nghiệm*

nhưng sự thành công của nghiên cứu hứa hẹn sẽ mở ra một quy trình mới giải quyết một số bất cập trong quá trình đăng kiểm xe cơ giới hiện nay.

**Từ khóa:** Kiểm định xe cơ giới; độ rơ vô lăng; quy trình đăng kiểm; chẩn đoán hệ thống lái; tự động hóa trong đăng kiểm.

## 1. INTRODUCTION

At present, the vehicle registry is carrying out inspecting the steering wheel free play according to Circular No.70/2015/TT-BGTVT of November 9, 2015 of the Minister of Communications and Transport. This is one of the items that determine the operational condition of a vehicle. However, the current method of measuring free play at the registries is completely manual and depends mainly on the inspectors. This problem has caused the lack of transparency in the registration process as well as the low efficiency of work. Therefore, this research will automate the process of measuring the steering wheel free play for vehicle registry in order to minimize the subjective factors and reduce the time to perform this work. This research content includes:

Survey of the current situation of inspecting the steering wheel free play at the registries.

Propose solutions and test the automatic system of measuring the steering wheel free play.

## 2. CONDUCT THE STEERING WHEEL FREE PLAY MEASURING SYSTEM

### 2.1. The situation of free play inspection

Steering wheel free play is an important parameter that indicates the wear of the steering system, including wear of steering gear, joints in the steering drive and suspension [1].

Inspecting the free play is in the part of the steering wheel of steering system inspection in vehicle registration process, issued by the Ministry of Transport and attached in Appendix I. Inspecting items described in *Figure 1* include: Start engine with power steering, make guide wheel in a

straight position, the inspectors turn the steering wheel to one side until the guide wheel start to shift to determine the point A'. Next, reverse the way to determine the point A'' and measure the arc M called the arc of free play. Then, measure the diameter D of the steering wheel. If the arc M exceeds 1/5 of the diameter D, the system is not up to standard and the vehicle is not certified [2].

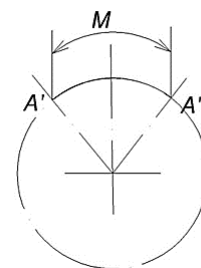

*Figure 1. The free arc of the steering wheel*

### 2.2. Proposal for free play measuring

The way to measure the steering wheel free play is described in *Figure 2*.

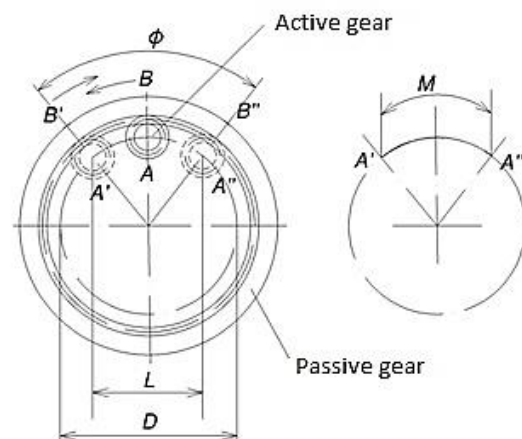

*Figure 2. Free play measuring principle*

Accordingly, the measuring principle is based on the analysis of the movement of the mated gear teeth. As shown in *Figure 2*, the point A is the center of the active gear which is held constant. When the gear rotates

counterclockwise, the point B on the passive gear is shifted to the left. When the active gear stops rotating, the point B on the passive gear will have a new position of B'. Corresponding to the point B', the center A of the active gears will have a new virtual center point A'. Next, when the active gear is reversed, the point B' on the passive gear shifts to the right. When the active gear stops rotating, it stops at the point B''. We also have a point A'' as the virtual center point of the active gear. From the points A' and A'' above, we can calculate the length M of the arc A'A'', the rotation angle  $\varphi$ , the length L of the arc A'A'. In there, L is the displacement of the virtual center points of the active gear. On the other hand, we also calculate the diameter D through the center of the active gear based on the structure of the gears. The ratio L/D is the value to estimate the steering wheel free play. Thus, with the above principle, the value of the ratio L/D that we have calculated will show that the steering wheel free play completely does not depend on the size of the diameter of the steering wheel because the ratio between the chord and the diameter is the constant value at the same rotation angle  $\varphi$ . According to the Ministry of Transport, the displacement of one point on the steering wheel shall not exceed 1/5 of the diameter of the steering wheel, which means the ratio  $L/D < 1/5$ . From **Figure 2** we have:

$$\sin\left(\frac{\varphi}{2}\right) = \frac{L}{D} \quad (1)$$

On the other hand,  $L/D < 1/5$ . From there, we have:

$$\sin\left(\frac{\varphi}{2}\right) \leq \frac{1}{5} = 0.2 \quad (2)$$

And we calculate the free driving angle in standard:

$$\varphi < 23^\circ \quad (3)$$

In order to estimate the steering wheel free play, we just need to determine the rotation angle  $\varphi$  of the steering wheel. Applying the above principle, the research team proposed the use of one direction electric motor driving the steering wheel

rotating around its shaft, using angle sensors mounted on the steering shaft to determine the rotation angle  $\varphi$ , using an ultrasonic sensor to determine the displacement of the guide wheel. After determining, if the angle  $\varphi < 23^\circ$ , it is standardized.

### 2.3. Making and Testing the system

The automatic system of measuring the steering wheel free play controls the steering wheel rotation, measures rotation angle and detecting displacement of guide wheel to calculate the free play as designed in the block diagram shown in **Figure 3**:

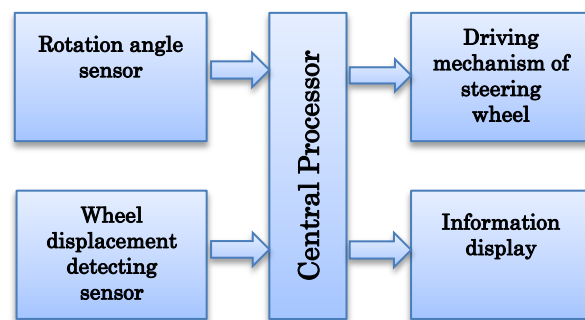

**Figure 3.** Block diagram of the system

In the block diagram shown in **Figure 3**, the rotation angle sensor will control the rotation angle of the steering wheel and sends the data back to the central processor. The displacement detecting sensor of the active wheel will detect when the wheel shifts to determine the free rotation angle of the steering wheel. The driving mechanism is equipped with electric motors to actuate. At the same time the information display will display the current test data. When the process starts, the controller controls rotation motor in a clockwise direction, and the angle sensor controls the rotation angle and the ultrasonic sensor controls shift of guide wheel. When guide wheel start to shift, stop the motor, record the steering wheel angle and reverse the steering wheel until the guide wheel start to shift. The rotation angle of the steering wheel between the first shift and the second shift is the free rotation angle or the steering wheel free play.

The displacement detecting sensor uses the US-015 ultrasonic distance sensor. The

sensor is positioned near the guide wheel when the wheel starts to move and the sensor detects and transmits to the central processor. US-015 is shaped like **Figure 4** and parameters as **Table 1**. [3].

**Table 1.** US-015 specifications

TT	Parameters	Value
1	Operate voltage	5 [VDC]
2	Working temperature	0 ~ 70 [°C]
3	Sweep angle	< 15 [°]
4	Detection range	2 ~ 700 [cm]
5	Accuracy	0,3 + 1% [cm]
6	Dimension	45x20x1,6[mm]



**Figure 4.** Wheel displacement detecting sensor

The return signal of the US-015 sensor is a pulse width  $d$  [ $\mu$ S] equal to the time of sound wave transmission. From there we have a Eq. that determines the distance  $L$  from the directional wheel sensor as Eq. (4).

$$L = \frac{d}{2} C \quad (4)$$

$C$  is the speed of sound wave in dry air is calculated using the Eq. (5) [4] as follows:

$$C = 331,45 \sqrt{1 + \frac{t}{273}} \quad (5)$$

In the Eq. (5),  $t$ [°C] is the environment sound transmission temperature or temperature at the time of the measurement.

From there, at each cycle the central processor will control the distance from the rim of the guide wheel to the position of the sensor. When there is a displacement of the

guide wheel, the distance  $L$  will change within the limits of recognition of US-015.

The driving mechanism in the diagram is a three-spoke grip mounted on the steering wheel by three screws as shown in **Figure 5**.

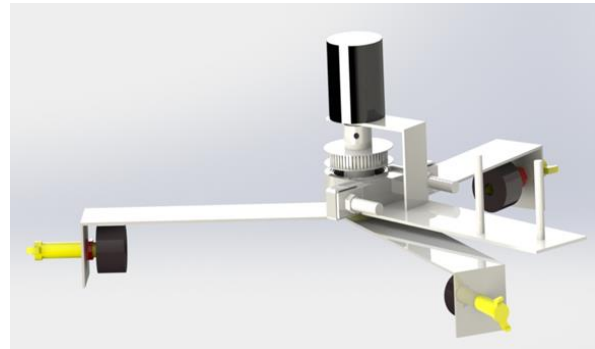

**Figure 5.** The driving mechanism

The steering wheel is driven by an electric motor, transmitting to the grip by gear mechanism. At the joint, place a LPD3806-400BM-G5-24C relative encoder with 600 pulses / round to measure the rotation angle [5]. Thus, the sensor can measure the rotation angle of the steering wheel with the accuracy of  $\Delta\varphi = 360/600 = 0.6$  degrees.

The driving mechanism is mounted on a rigid base on the floor that is able to freely shift vertically and horizontally to adjust the structure to suit the steering wheel height of each vehicle. The complete structure is designed as shown in **Figure 6**.



**Figure 6.** Driving mechanism & angle detecting

### 3. TEST STEERING WHEEL MEASURING SET

#### 3.1. Experiment

The system was made experimentally at the automobile mechatronics laboratory according to the design idea. The system was initially tested on the Toyota Vios. The experimental scene is shown in *Figure 7*.



*Figure 7. System test on Vios*

The driving mechanism is fixed to the steering wheel by a three-spoke mechanism which adjusts the rotation center as shown in *Figure 8*.



*Figure 8. Experimental driving mechanism*

The steering wheel displacement detecting sensor is located near the guide wheel and transmits data to the central processor via wireless transmission as shown in *Figure 9*.



*Figure 9. Guide wheel controlling unit*

The central processor is mounted on the racks, near the driving motor to control the experiment easily because the system is not equipped with remote control. Installation position as shown in *Figure 10*.



*Figure 10. Central Controlling Unit*

#### 3.2 Test results

After the actual measurement on the car 30 times, we get the data table as *Table 2*.

*Table 2. The statistics of the steering wheel free play measurements on the Toyota Vios*

TT	Angle [°]	TT	Angle [°]	TT	Angle [°]
1	4	11	3	21	3
2	4	12	3	22	4
3	4	13	3	23	3

TT	Angle [°]	TT	Angle [°]	TT	Angle [°]
4	2	14	3	24	4
5	4	15	3	25	2
6	4	16	3	26	4
7	2	17	2	27	1
8	3	18	3	28	2
9	3	19	3	29	0
10	3	20	4	30	1

Because the test was conducted on Toyota Vios 2009 equipped with electronic power steering system with very small steering wheel free play, so when using the error calculation [6] from the data table collected we received the average steering wheel angle was  $2.9^\circ$  with a variance of  $1.06^\circ$  and a

standard deviation of  $1.02^\circ$ , if compared with a  $23^\circ$  steering wheel free play limitation, the deviation is relatively large. This deviation is due to the sensitivity of the sensor and the oscillation of the system.

#### 4. CONCLUSION

Automating the process of measuring steering wheel free play was feasible and able to measure a free angle of the steering wheel. However, this is only the first step in testing the feasibility of the proposed project without assessing the reliability of the measurement and the stability of the system has not been determined. However, the success of the experiment has shown that it is possible to create a system that realize this process within the framework of the permissible technique.

#### REFERENCES

- [1] Tran Thanh Hai Tung, Nguyen Le Chau Thanh, *Chẩn đoán trạng thái kỹ thuật ô tô*, 2006.
- [2] Appendix I, Guidance for Circular 70/2015/TT-BGTVT November 09, 2015 issued by Minister of Transport.
- [3] <http://www.industrial-electronics.com/>
- [4] Environmental Effects on the Speed of Sound, DENNIS A. BOHN, Rane Corporation, Mukilteo, WA 98275 USA
- [5] LPD3806-400BM-G5-24C Datasheet
- [6] Tran Quoc Hung, *Dung sai – kỹ thuật đo*, Ho Chi Minh City National University Press, 2012.

#### Corresponding author:

Le Quang Vu

Ho Chi Minh City University of Technology and Education, Vietnam

Email: vulq@hcmute.edu.vn