

THE APPLICATION OF DIGITAL SIGNAL PROCESSING METHOD TO DEVELOP AN ALGORITHM FOR NEUTRON-GAMMA PULSE SHAPE DISCRIMINATOR

ỨNG DỤNG KỸ THUẬT XỬ LÝ TÍN HIỆU SỐ (DSP) ĐỂ XÂY DỰNG THUẬT TOÁN PHÂN BIỆT XUNG NEUTRON-GAMMA

Dang Hong Ngoc Quy, Pham Ngoc Tuan, Tuong Thi Thu Huong, Nguyen Nhi Dien
Nuclear Research Institute, Da Lat, Lam Dong

Received 11/10/2017, Peer reviewed 15/10/2017, Accepted for publication 01/11/2017.

ABSTRACT

The measurement of neutron energy has been required in many fields of sciences such as nuclear reactor equipment, particle physics, material research and so on. However, the contribution of gamma background into the spectrum causes neutron spectrum to be less accurate. Therefore, the discrimination of gamma-ray events in neutron spectrum is essential. As the difference in the output signal of detector when interacting between neutron and gamma rays that allows establish an algorithm for separating neutron-gamma. In this article, algorithm for digital implementation of the charge-comparison method for n/γ discrimination based on digital signal processing technique is described. The development of an FPGA based digital signal processing system has been undertaken for this application. In particular, the development kit named Spartan 6 FPGA was used as a hardware for the development of a pulse shape discriminator, and is equipped with ADC 6645 14 bit-100 MSPS. The entire system has been tested with He-3 counter, using thermal neutron source from Da Lat reactor.

Keywords: PSD; Pulse Shaping Discriminator; He-3 counter; Digital Signal Processing; Charge comparison method (CCM).

TÓM TẮT

Việc ghi đo chính xác phổ năng lượng neutron được yêu cầu trong nhiều lĩnh vực nghiên cứu. Tuy nhiên, các phép đo phổ neutron thường có độ phân giải thấp do đóng góp của bức xạ gamma. Do đó, yêu cầu phân biệt nền thông gamma trong phổ neutron là cần thiết. Từ bản chất tương tác của tia bức xạ gamma-neutron có cùng mức năng lượng với vật liệu trong đầu dò, phần diện tích đuôi xung của neutron sẽ lớn hơn gamma. Dựa trên cơ sở lý thuyết này, nhóm nghiên cứu đã tiến hành xây dựng thuật toán phân biệt dạng xung và dựa trên kỹ thuật xử lý tín hiệu số (DSP) để thiết kế, chế tạo khối phân biệt dạng xung neutron – gamma nhúng vào chip FPGA. Hệ thống hoàn chỉnh đã được kiểm tra, đo đạc với đầu dò nhấp nháy dùng ống đếm Heli-3 và dòng neutron nhiệt từ lò phản ứng hạt nhân Đà Lạt.

Từ khóa: PSD; Phân biệt dạng xung; Ống đếm He-3; Xử lý tín hiệu số; Phương pháp so sánh diện tích (CCM).

1. INTRODUCTION

There are usually three sources of background noise in neutron detection: alpha particles, beta particles, and high-energy photons (γ -rays). Alpha and beta particles can be easily shielded by various materials. However, γ -rays pass through physical

barriers and when mixed with neutrons in the detection environment, they behave almost the same as neutrons and make it uncertain whether neutrons are detected or γ -rays [1]. Therefore, various methods of separating the neutrons from the gammas have been developed, including both analog and digital approaches such as zero crossing, constant

fraction discriminator [2,3], charge comparison [3,4] frequency gradient analysis [5], rise time discrimination, pattern recognition [6], etc.

In this paper, one of these methods is carried out and established to develop an optimum algorithm for pulse shape discriminator based on the different interactions between gamma and neutron rays with the material of detectors. Thanks to Digital Signal Processing technique and Field Programmable Gate Arrays (FPGA) devices, A PSD module is designed and fabricated.

In the recent period at NRI, most of the radiation measurements have been digitalized such as Digital multichannel analyzer (DMCA) and coincidence measurement system. However, the application of digital signal processing (DSP) techniques to discriminate pulses has not been studied so far. Novel DSP methods are introduced and studied in this article.

2. CONTENTS

2.1. Materials and methods

This method shows that gamma-ray pulses have shorter tails than neutron pulses when interacting with the material of detectors and the ratio of these pulses will be approximately constant for pulses of common shape, independent of pulse amplitude [1]. An approach to the design is based on independent measurements of the integrated charge over two different time regions of the pulse.

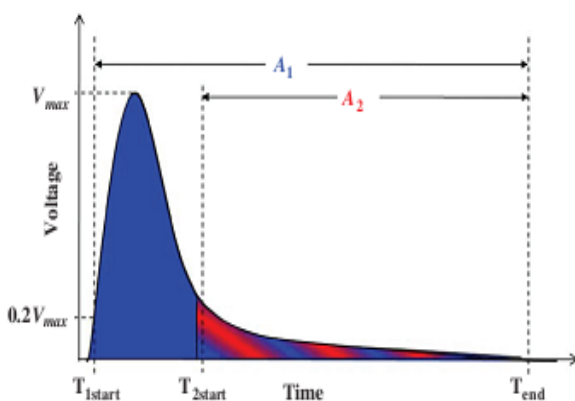

Figure 1. Illustration of the pulse shape from detector.

The ratio of tail-to-total integrals is calculated as follow:

$$R = \frac{\text{Tail integral}}{\text{Total integral}} = \frac{A_2}{A_1} \quad (1)$$

The time intervals over which the total and tail integrals are calculated, these parameters can be modified to increase the performance of the PSD method.

From the figure 1, the total integral (A1) and tail integral (A2) are computed for each pulse and used for classification as a neutron or gamma-ray. Pulse timing was achieved by measuring the time at which the pulse reaches 20% of the pulse amplitude.

T_{1start} is the starting point of the total integral (A1) and T_{2start} is the starting point of the tail integral (A2) and T_{end} is the ending point of both. The timing for T_{2start} and T_{end} are decided empirically based on a specific detector used to achieve optimal results. Since pulses for heavy particles have a larger fraction of light in the tail, a larger ratio of tail-to-total will be obtained for neutrons compared to gamma rays.

The QRatio (R) for neutron pulses should be larger than the QRatio(R) for gamma ray pulses for the same total charge deposited. The FOM is calculated from the histogram of the Qratio versus peak height data. The FOM is defined as (note that this definition assumes that the pulse distributions are Gaussian):

$$FOM = \frac{S}{\delta_{neutron} + \delta_{gamma}} \quad (2)$$

$S \equiv$ the distance between the gamma ray and neutron peaks

$\delta \equiv$ the full width at half maximum (FWHM) of the peaks.

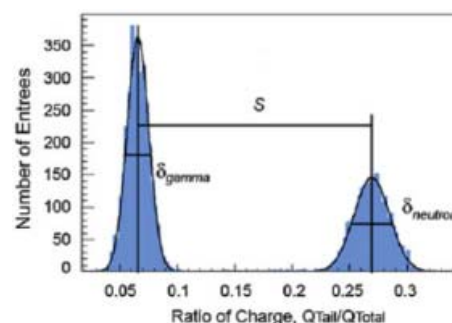

2.2 Results

The design and implementation of the digital pulse shape discriminators is shown in figure 2.

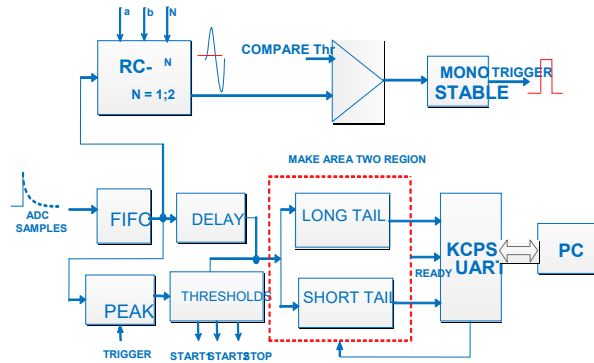

Figure 2. The block diagram of Digital Pulse Shape Discriminator

From the method that was mentioned above, the digital pulse shape discriminator was fabricated. This system consists of various component modules. All components have been designed, implemented and configured into the FPGA by using of Xilinx ISE design suit 14.1 software tools.

High technology development has created a variety of techniques such as flash analog digital convertor, field programmable gate array (FPGA), and dedicated digital signal processing (DSP) circuits. That makes the PSD based on digital signal processing technique widely applied. In modern DSP-based PSD systems, pulses from detector are digitized by fast sample ADC named AD6645, the sample rate is 100 MSPS. The output from ADC are then stored in FIFO and analyzed by PSD system to give the A1 and A2 that captured by Micro-processor named KCPSM6 for sending to PC via the RS232 communication port.

CR- (RC)^N is a Semi-Gaussian filter which consists of one CR differentiator stage and N order RC integrator stages in the series combination network. The output of RC- (CR)^N filter is compared with adjustable threshold in order to reduce noise and create a trigger. This trigger signal is used to initialize all components in PSD. The total

integral of the input pulse A1 is given by long tail area processor module while the short integral of the input pulse A2 is given by short tail area processor module. Both of the two values A1, A2 are transmitted to PC and displayed on the screen by application software program written in LabView.

In this design, the communication between PSD and PC via RS232 COM Port under the controlling of micro-processor

The installation of measurement configuration in order to test the algorithm for PSD is shown in figure 3.

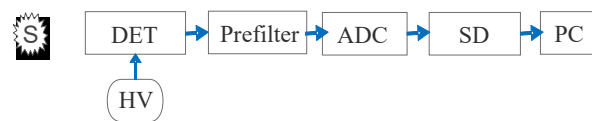

Figure 3. The set up of PSD system

In this experiment:

- + Source: thermal neutron source from Da Lat reactor, neutron flux is around 10^6 s^{-1} .
- + Detector: Heli-3 counter.
- + The value of 3 thresholds:
 - T1start: 20% of peak value
 - T2start: 50% of peak value
 - Tstop: 5% of peak value

The integral of two regions are calculated automatically by PSD module. After that, the data is handled and plotted with excel software which is illustrated in figure 4.

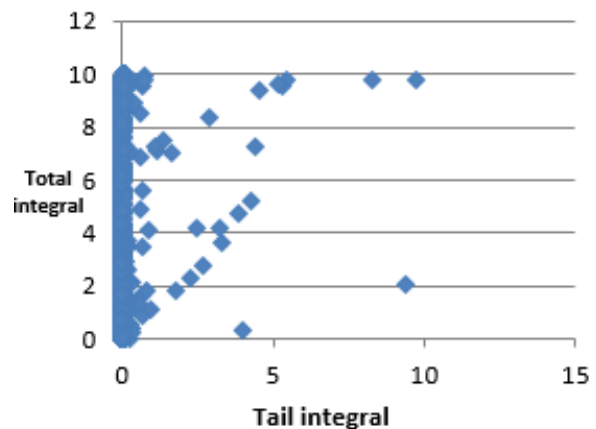

Figure 4. Tail and total pulse integrals for measured pulses from Heli-3 counter

2.3 Discussion

The sampling rate of the PSD is 100 MHz and that give a time resolution of 10 ns. For small pulses the time resolution was a limiting factor since 10 ns meant that the data points were taken far to infrequently to catch the entire structure of the pulse. Therefore, to improvement the resolution, the GHz sampling rate ADC should be used. Recommendation for further research, the possibility of pulse shape analysis to separate gammas and neutrons for organic

scintillation detectors will be conducted, other neutron sources should be studied. The pie-up rejection is not still included in this method so there will be unusual points as figure 4.

3. CONCLUSION

In this research, Digital pulse processing algorithm for discrimination of neutrons and γ rays in Heli-3 counter has been developed. In conclusion, the effects of data resolution and sampling rate on each method were discussed.

REFERENCES

- [1] Neutron/gamma-ray measurement and discrimination PhD thesis Moslem Amiri, pp. 1–2, 2014
- [2] M. L. Roush, M. A. Wilson, and W. F. Hornyak, “Pulse shape discrimination,” *Nucl. Instruments Methods*, vol. 31, no. 1, pp. 112–124, 1964.
- [3] E. Bayat, N. Divani-Vais, M. M. Firoozabadi, and N. Ghal-Eh, “A comparative study on neutron-gamma discrimination with NE213 and UGLLT scintillators using zero-crossing method,” *Radiat. Phys. Chem.*, vol. 81, no. 3, pp. 217–220, 2012.
- [4] J. Cerny, Z. Dolezal, M. P. Ivanov, E. S. Kuzmin, J. Svejda, and I. Wilhelm, “Study of neutron response and n- γ discrimination by charge comparison method for small liquid scintillation detector,” *Nucl. Instruments Methods Phys. Res. Sect. A Accel. Spectrometers, Detect. Assoc. Equip.*, vol. 527, no. 3, pp. 512–518, 2004.
- [5] G. Liu, M. J. Joyce, X. Ma, and M. D. Aspinall, “A digital method for the discrimination of neutrons and rays with organic scintillation detectors using frequency gradient analysis,” *Nucl. Sci. IEEE Trans.*, vol. 57, no. 3, pp. 1682–1691, 2010.
- [6] Takaku, D., Oishi, T. & Baba, M. (2011). Development of neutron-gamma discrimination technique using pattern-recognition method with digital signal processing. *Nuclear Science and Technology*, 1, 210-213.

Corresponding author:

Dang Hong Ngoc Quy

Nuclear Research Institute, 01 Nguyen Tu Luc, Da Lat, Lam Dong

Email: danghongngocquy@gmail.com