

APPLICATION OF AN SVC TO ENHANCE THE STABILITY OF THE DFIG-BASED WIND TURBINE GENERATOR FED TO POWER GRID

ỨNG DỤNG THIẾT BỊ BÙ NGANG (SVC) ĐỂ NÂNG CAO ỔN ĐỊNH ĐỘNG CỦA MÁY PHÁT ĐIỆN GIÓ NGUỒN ĐÔI (DFIG) KẾT NỐI VỚI LƯỚI ĐIỆN

Truong Dinh Nhon¹, Pham Van Hiep¹, Bui Van Tri², Ho Duc Loc³

¹*Ho Chi Minh City University of Technology and Education*

²*Ho Chi Minh City Vocational College of Technology*

³*Ho Chi Minh City University of Technology*

TÓM TẮT

Bài báo trình bày việc ứng dụng thiết bị bù ngang (SVC) để cải thiện ổn định động của máy phát cảm ứng nguồn đôi (DFIG) tuabin gió (WT) có kết nối với lưới điện. Hệ thống điện năng lượng gió sử dụng trong nghiên cứu có công suất 9-MW bao gồm 6 x 1.5-MW máy phát DFIG kết nối với bus 110 kV của hệ thống điện. Kết quả mô phỏng được thực hiện trong phần mềm MATLAB với các điều kiện nhiễu khác nhau. Có thể kết luận từ kết quả mô phỏng rằng SVC có thể giúp tăng cường ổn định động của hệ thống nghiên cứu.

Từ khóa: *Máy phát cảm ứng nguồn đôi (DFIG), máy phát điện gió (WTG), thiết bị bù ngang (SVC), ổn định.*

ABSTRACT

This paper presents the application of a Static Var Compensator (SVC) to improve the dynamic stability of the Doubly-Fed Induction Generator (DFIG)-based Wind Turbine Generator (WTG) fed to power grid. The studied 9-MW wind power system includes 6x1.5-MW DFIG-based WTG connected to bus 110-kV of the power system. Simulation results are performed in commercial MATLAB software with different disturbance conditions. It can be concluded from simulation results that the effect of the proposed SVC can enhance the stability of the studied system.

Keywords: *Doubly-Fed Induction Generator (DFIG), Wind Turbine Generator (WTG), Static Var Compensator (SVC), Stability.*

I. INTRODUCTION

With the increasing penetration of wind power into electrical grids, Doubly-Fed Induction Generator (DFIG)-based wind turbines (WTs) are largely deployed due to their variable speed feature and hence influencing system dynamics. This has created an interest in developing suitable models for DFIG to be integrated into power system studies. The continuous trend of having high penetration of wind power, in recent years, has made it necessary to introduce new practices.

DFIG is the most employed generator due to many merits of it such as, high efficiency compared to direct drive wind power system with a full-scale power converter since only about 20% of power flowing through power converter and the rest through stator without power electronics, capability of decoupled control active and reactive power for better grid integration [1]. However, by connecting stator windings directly to the power grid, it is extremely sensitive to grid faults. To improve the stability of the power systems, fixed

capacitor banks are usually used. However, fixed capacitor cannot adjust the supporting reactive power to grid to maintain the voltage stable. In [2], a new topology structure of Static Var Compensator (SVC) has been proposed which is used to correct the unbalanced problems and improve the reliability of power systems. An SVC and a thyristor-controlled series compensator (TCSC) were employed in a single-machine infinite-bus (SMIB) system to improve transient voltage stability

of an asynchronous wind farm [3]. In which, the SVC was able to offer reactive power to maintain the transient stability while the TCSC was able to promote the terminal voltage and effectively improve low-voltage ride through (LVRT) capability.

In this paper, an SVC is proposed to regulate voltage at its terminals by controlling the amount of reactive power injected into or absorbed from the power system for replacing the fixed capacitor.

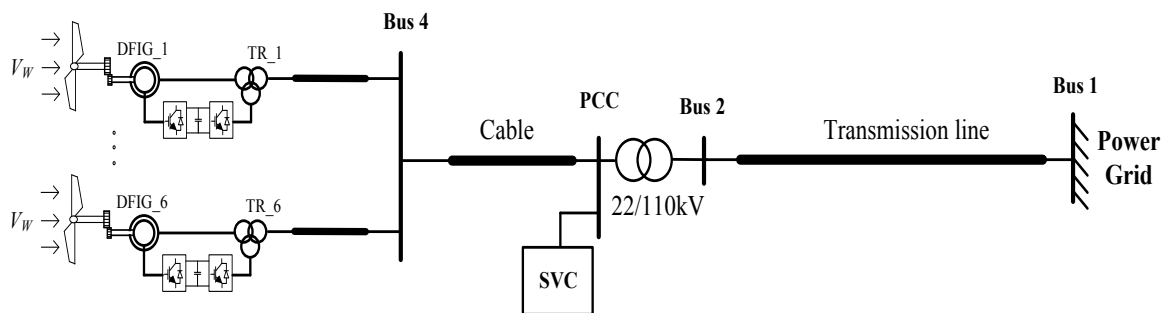

Fig. 1: Configuration of the studied system.

II. SYSTEM CONFIGURATION AND MATHEMATICAL MODELS

Fig. 1 shows the configuration of the studied system. A 9-MW wind farm consisting of 6 x 1.5-MWWTs connected to a 22-kV distribution system exports power to a 110-kV power grid through a 30-km, 22-kV feeder. An SVC is proposed to connect to the PCC to supply the adequate reactive power to the system.

WTs use a DFIG consisting of a wound rotor induction generator and an AC/DC/AC IGBT-based PWM converter. The stator winding is

connected directly to the 50-Hz grid while the rotor is fed at variable frequency through the AC/DC and DC/AC converters.

1. DFIG-based Wind Turbine Model

In this paper, a DFIG model shown in Fig. 2 developed in a dq -axis synchronous reference frame with an assumption of neglecting the stator-winding transient effects is employed [4].

By neglecting the stator-winding transients, the pu voltage-current equations of the stator windings and the rotor windings of a wind DFIG are given by

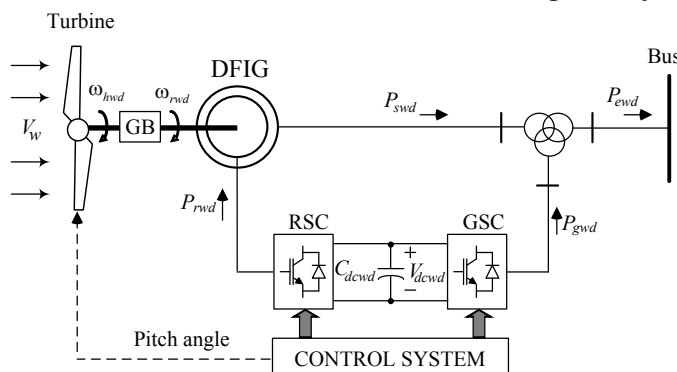

Fig. 2. One-line diagram of wind DFIG driven by a WT.

$$v_{dswd} = -R_{swd}i_{dswd} - \omega_{rwd}\Psi_{qswd} \quad (1)$$

$$v_{qswd} = -R_{swd}i_{qswd} + \omega_{rwd}\Psi_{dswd} \quad (2)$$

$$v_{drwd} = R_{rwd}i_{drwd} - s_{wd}\omega_{rwd}\Psi_{qrwd} + \frac{1}{\omega_b}p(\Psi_{drwd}) \quad (3)$$

$$v_{qrwd} = R_{rwd}i_{qrwd} + s_{wd}\omega_{rwd}\Psi_{drwd} + \frac{1}{\omega_b}p(\Psi_{qrwd}) \quad (4)$$

Where Ψ_{swd} and Ψ_{rwd} are the pu flux linkages of the stator windings and the rotor windings, respectively.

The pu electromagnetic torque of the wind DFIG can be determined by

$$T_{ewd} = L_{mwd}(i_{qrwd}i_{dswd} - i_{drwd}i_{qswd}) \quad (5)$$

Where i_{swd} and i_{rwd} are the pu stator-winding and rotor-winding currents of the wind DFIG, respectively.

Neglecting the power losses of the Rotor Side Converter (RSC) and the Grid Side Converter (GSC), the power balance equation for the back-to-back converter shown in Fig. 2 can be written as

$$P_{rwd} = P_{gwd} - P_{dcwd} \quad (5)$$

Where P_{rwd} and P_{gwd} are the active powers at the AC terminals of the RSC and the GSC, respectively while P_{dcwd} is the active power at the DC link. These three active powers can be expressed as follows.

$$P_{rwd} = v_{drwd}i_{drwd} + v_{qrwd}i_{qrwd} \quad (6)$$

$$P_{gwd} = v_{dgwd}i_{dgwd} + v_{qgwd}i_{qgwd} \quad (7)$$

$$P_{dcwd} = V_{dcwd}I_{dcwd} = (V_{dcwd}C_{dcwd})p(V_{dcwd}) \quad (8)$$

Substituting (5)-(7) into (8), the pu differential equation of the DC link can be obtained as

$$\begin{aligned} (V_{dcwd}C_{dcwd})p(V_{dcwd}) &= v_{dgwd}i_{dgwd} + v_{qgwd}i_{qgwd} \\ &- v_{drwd}i_{drwd} - v_{qrwd}i_{qrwd} \end{aligned} \quad (9)$$

For normal operation of a wind DFIG, the input AC-side voltages of the RSC and the GSC can be effectively controlled to achieve the aims of simultaneous control of the output active power and reactive power.

2. SVC model

The proposed SVC in this paper is used for regulating the voltage at its terminals by compensating the proper amount of reactive power to power systems. The single-phase equivalent circuit of the SVC with thyristor-controlled reactor-fixed capacitor (TCR-FC) type was shown in Fig. 3 [5]. Fig. 4 shows the control block diagram for the equivalent susceptance B_{SVC} of the studied SVC. When the system voltage is lower than the reference value, the value of B_{SVC} of the SVC is positive to inject reactive power to the system; when the system voltage is higher than the reference value, the B_{SVC} of the SVC is negative to absorb reactive power from the power system. Assuming a balanced and fundamental frequency operation, the equivalent B_{SVC} of the SVC is a function of the firing angle α as shown below [6].

$$B_{SVC}(\alpha) = \frac{2\alpha - \sin(2\alpha) - \pi\left(2 - \frac{X_L}{X_C}\right)}{\pi X_L} \quad (10)$$

Where X_L and X_C are reactance of reactor and capacitor of SVC, respectively.

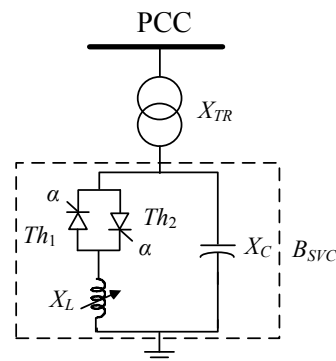

Fig. 3. One-line diagram of SVC.

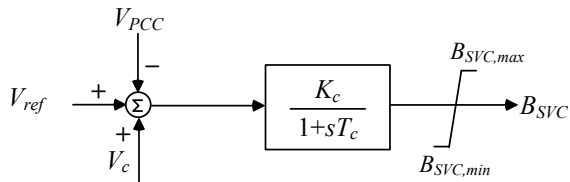

Fig.4. Control scheme of SVC.

III. COMPARISON BETWEEN FIXED CAPACITOR AND SVC

For estimating the advantages of the proposed SVC to the fixed capacitor, in this section, the nonlinear system model is employed to compare the damping characteristics contributed by the proposed SVC on stability improvement of the studied system subject to a severe disturbance. It is assumed that the WTG is operated at a wind speed of 8 m/s since this is the average offshore wind speed value in Vietnam. Simulation results of the proposed system are performed in MATLAB/Simulink toolbox.

Fig. 5 plots the comparative transient responses of the studied system without compensation (blue lines), with fixed capacitor (red dotted lines), and with the proposed SVC (black lines), respectively. The three-phase short circuit fault at the PCC is suddenly applied at $t = 0.5$ s and is cleared at $t = (0.5 + 1/60)$ s. In this case studied, the fault happened in 1/60s to warranty that the protection relay is inactive. It is clearly observed from the comparative transient simulation results that the transient responses of the studied system shown in Figs. 5(a)-(d) exhibit good damping performance when the proposed fixed capacitor and SVC are connected in the PCC are included in the system. When a fault is happened the system oscillated and quickly reaching their steady-state values.

IV. CONCLUSION

This paper has presented the comparative stability improvement of a DFIG-based WT

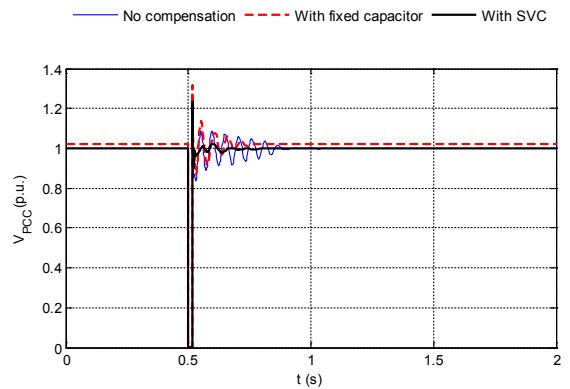

(a) Voltage at Bus 3

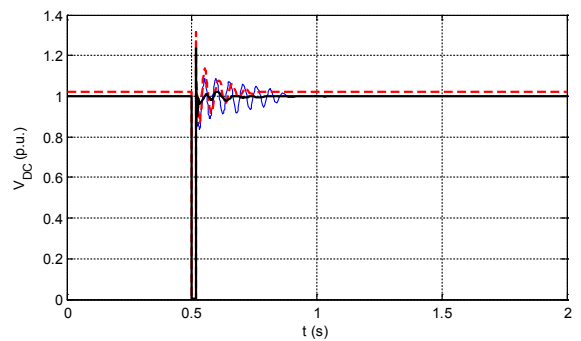

(b) DC link voltage of DFIG

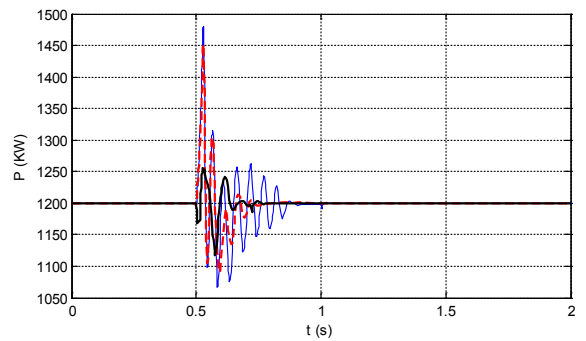

(c) Active power of DFIG

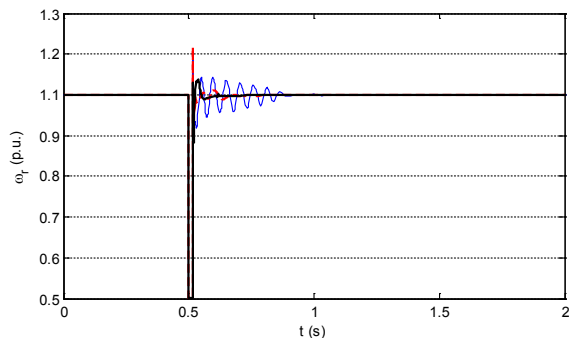

(d) Rotor speed of DFIG

Fig. 5: Transient responses of the studied system under a three-phase short-circuit fault.

fed to power systems. To supply the adequate reactive power to the system an SVC has been proposed to connect to the PCC of the studied system. Comparative time domain simulation results of the studied system subject to a three-phase short circuit fault at the connected bus have been systematically performed to

demonstrate the effectiveness of the proposed SVC on suppressing inherent oscillations of the studied system. It can be concluded from the simulation results that the proposed SVC has the best damping characteristics to improve the performance of the DFIG-based WT fed to the power system under a severe operating condition.

REFERENCES

- [1] A. Petersson, "Analysis, modeling and control of doubly-fed induction generators for wind turbines," Chalmers University of Technology, Goteborg, Sweden, 2005.
- [2] Z. Yu, Z. Jianhua, and Z. Aiguo, "A novel topology structure of SVC based on energy saving for unbalanced three phase compensation in low voltage power system," in *Proc. IEEE Region 10 TENCON Conference*, Jan. 2009.
- [3] Z. Hua, W. Hongfen, Q. Xiaoyan, X. Jian, W. Xiwen, and W. Song, "Improvement of transient voltage stability of the wind farm using SVC and TCSC," in *Proc. Power and Energy Engineering Conference (APPEEC)*, Mar. 2011.
- [4] L. Wang and D.-N. Truong, "Stability improvement of a DFIG-based offshore wind farm fed to a multi-machine power system using a static VAR compensator," in *Proc. IEEE IAS Annual Meeting*, 7-11 October 2012, Las Vegas, NV, USA.
- [5] Y. Chang, Z. Xu, G. Chen, and J. Xie, "A novel SVC supplementary controller based on wide area signals," in *Proc. IEEE Power Engineering Society General Meeting*, 2006.
- [6] D.-N. Truong and V.-T. Ngo, "Study of the dynamic stability enhancement of PMG-based wind turbine generator fed to power grid using an SVC," *Journal of Science & Technology*, vol. 101, pp. 82-86, 2014.